

harman/kardon

PA5800/Signature 2.1

Multichannel Power Amplifier



Harman Consumer Group
250 Crossways Park Drive
Woodbury, N.Y. 11797
1-800 645-7484

H A Harman International Company

Part No.: 1112-PA5800/2.1 Rev A 7/99

TABLE OF CONTENTS

FEATURES.....1	PA5800 POWER SWITCH PCB.....16
SPECIFICATIONS.....2	PA5800 POWER AMPLIFIER PCB.....17
FRONT PANEL CONTROLS3 PA5800/Signature 2.1	Signature 2.1 POWER SWITCH/INDICATOR PCB.....18 Rev B9 & D
REAR PANEL CONNECTIONS.....4	Signature 2.1 POWER AMPLIFIER PCB19
INSTALLATION4	PA5800 (120V) TRANSF. WIRING REV B.....20
OPERATION.....6	Signature 2.1 (120V) TRANSF. WIRING21
IDLE CURRENT ADJUSTMENT6 PA5800/Signature 2.1	Signature 2.1 (230V) TRANSF. WIRING REV 022
TROUBLE SHOOTING7	Signature 2.1 (230V) TRANSF. WIRING REV B.....23
PROTECT MODE7	INTEGRATED CIRCUITS24
PA5800 MECHANICAL EXPLODED VIEW8	PA5800 POWER SWITCH SCHEMATIC (1 of 1).....25
PA5800 MECHANICAL PARTS LIST.....9	PA5800 POWER AMPLIFIER SCHEMATIC (1 of 1)....26
PA5800 PACKING EXPLODED VIEW.....9	Signature 2.1 POWER SWITCH/INDICATOR.....27 SCHEMATIC (1 of 1)
Signature 2.1 MECHANICAL EXPLODED VIEW10	Signature 2.1 POWER AMP SCHEMATIC (1 of 5).....28
Signature 2.1 MECHANICAL PARTS LIST.....11	Signature 2.1 POWER AMP SCHEMATIC (2 of 5).....29
Signature 2.1 PACKING EXPLODED VIEW.....11	Signature 2.1 POWER AMP SCHEMATIC (3 of 5).....30
PA5800 ELECTRICAL PARTS LIST.....12	Signature 2.1 POWER AMP SCHEMATIC (4 of 5).....31
Signature 2.1 ELECTRICAL PARTS LIST.....14	Signature 2.1 POWER AMP SCHEMATIC (5 of 5).....32

FEATURES

The Harman Kardon PA5800/Signature2.1 is a flexible, state-of-the-art audio power amplifier designed to deliver high performance for use in home theater or music reproduction applications. The following are among its many features:

- Designed and manufactured in the United States.
- High-current output capability.
- Toroidal Power Transformer with individual secondary wiring and individual DC power supplies for each channel assure maximum output and minimum interaction between channels.
- Ultrawide Bandwidth Design
- Low Negative Feedback
- Low Harmonic and intermodulation distortion
- High-current power supply
- Massive Heat Sinks for quiet convection cooling
- Remote Turn-on/Turn-off circuitry with select Harman Kardon product or through optional accessories

SPECIFICATIONS

PA5800

Power Requirements:	.120V version: 120VAC, 50/60Hz 230V version: 230VAC, 50Hz
High Current Capability:	73Amps
Power Output:	5 x 80watts @ 8 ohms 20Hz - 20kHz, <0.05% THD, All Channels Driven
Frequency Response:	.022Hz - 160kHz - 3dB at 1 watt
THD/IMD:	Less than 110 at rated output
Power Bandwidth:	<5hz - 160kHz
Input Sensitivity:	1volt for rated output
Input Impedance:	33kohms
Remote Trigger Voltage:	6 - 12volts DC (tip of plug must be "positive"(+))
Remote Trigger Impedance:	20Kohms
S/N Ratio (unweighted):	>100dB
S/N Ratio (weighted):	>115dB
Channel Separation	
(1kHz):	>95dB
(10kHz)	>80dB
Damping Factor	
(40Hz):	1.54%
(1hz):	1.46%
Idling Power Consumption:	26watts
Full Power Consumption:	773watts
Dimensions (H x W x D):	6-1/8 x 17-3/8 x 15-1/2 inches 155 x 440 x 394 mm
Weight:	30 lbs /13.6 kg

Signature 2.1

Power Requirements:	.120V version: 120VAC, 50/60Hz 230V version: 230VAC 50Hz
Power Output:	5 x100watts @ 8 ohms 20Hz - 20kHz, <0.03% THD, All Channels Driven 5 x 150 watts @ 4 ohms 20Hz - 20kHz, <0.03% THD, All Channels Driven
High-Current Capability:	100Amps
Frequency Response:	<1hz - >160kHz
Power Bandwidth:	<1hz - >160kHz
THD/IMD:	<0.03% at rated output
Crosstalk	<-87 dBr between any two channels at maximum output
Negative Feedback:	<25dB
Input Impedance:	33Kohms
Input Sensitivity:	1volt for rated output
Remote Trigger Voltage:	6 - 12volts DC (tip of plug must be "positive"(+))
Remote Trigger Impedance:	20Kohms
Dimensions (H x W x D):	7 ½ x 17 ¼ x 15 ¼inches 191 x 438 x 387 mm
Weight:	47lbs/21 kg

Signature 2.1 & PA5800 FRONT PANEL CONTROLS

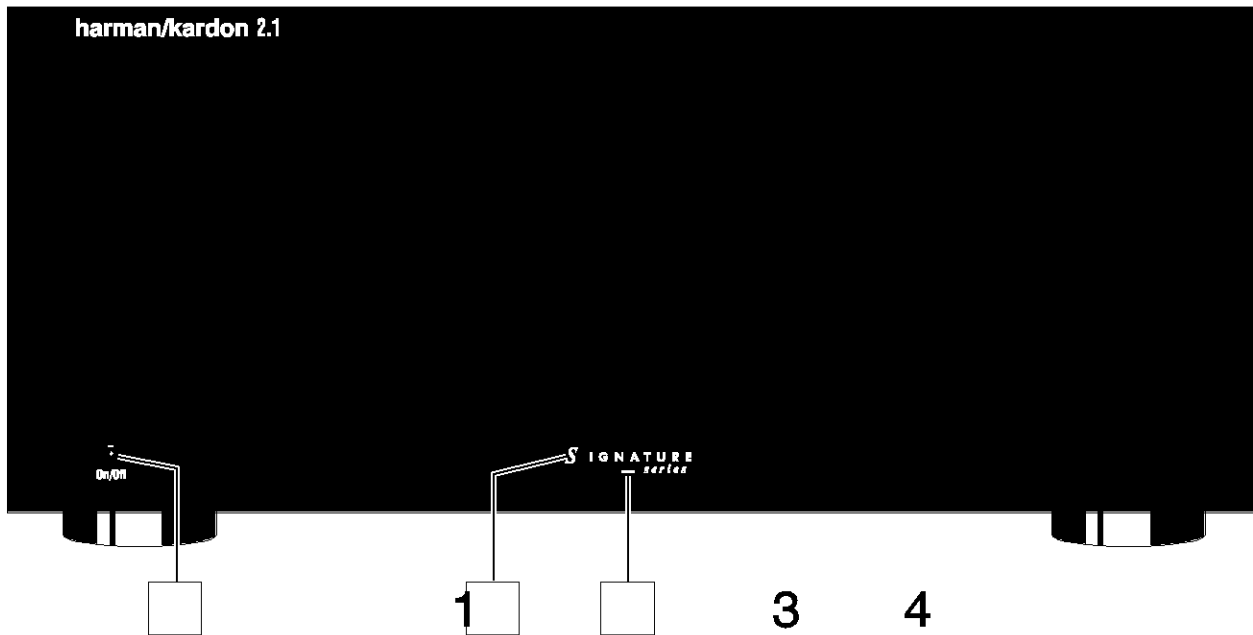

1. Power Switch: Press this switch to turn the PA5800/Signature 2.1 on for manual operation, or place it in the standby mode for automatic/remote turn-on when the unit is connected to a device with a compatible trigger circuit.

2. Power On Indicator: The color of this indicator varies with the status of the PA5800. It is red when the unit is off and in manual operation, amber in standby mode for automatic/remote turn-on when the PA5800 is connected to a device with a compatible trigger circuit, and green when the unit is on.

3. Power On Indicator: When the word Signature is illuminated in blue, the 2.1 is in a normal operating condition.

4. LED Indicator: The color of this indicator varies with the status of the 2.1. It is red when the unit is off and in manual operation, amber in the standby mode, and flashing green during warm-up. If the indicator flashes and alternates between red and amber, the 2.1 is in the protect mode, indicating a problem in the unit or connections to the speakers.

REAR PANEL CONNECTIONS

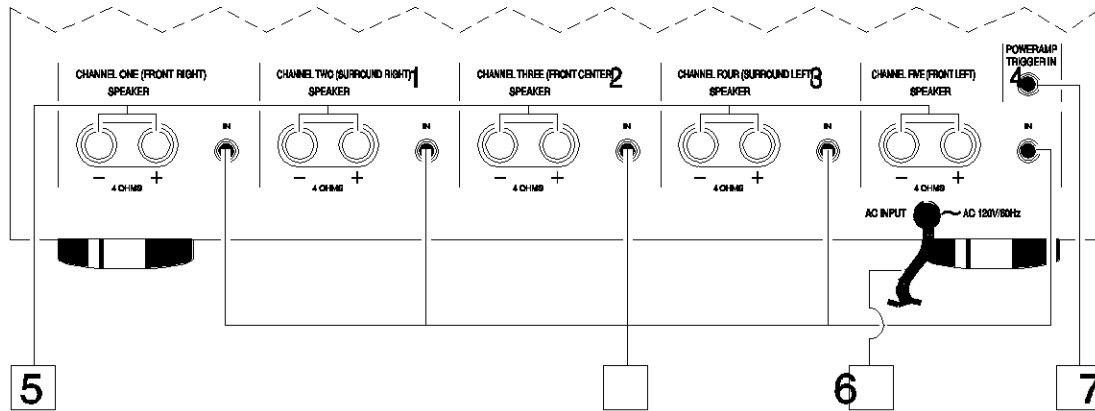

5. Speaker Outputs: Connections from these terminals should be made to the appropriate speakers in your system.

6. Audio Inputs: Connect the outputs of the PT2500, ADP303 or other surround processor, preamplifier or decoder to these jacks.

7. AC Power Cord: Connect this plug to a wall-mounted AC outlet. Due to the current draw of the PA5800/2.1, it is NOT recommended that the accessory outlets on the back of the audio/video components be used to power this product.

8. Remote Amp Trigger In: Connect this jack to the matching trigger output on a PT2500 or other compatible device to have the PA5800/2.1 automatically turn on when the devices are activated.

INSTALLATION

NOTE: When making any connections between source components, processor or preamplifiers and the PA5800/2.1, or when making any connection to speakers, be certain that both the input device and the unit are turned off. To ensure that there will be no unwanted signal transients that can damage equipment or speakers, it is always best to unplug all equipment from AC power outlets before making any connection. Modern electronic products often have a “standby” mode that may be activated even though the product may appear to be turned off.

Power Control Connections

The Harman Kardon PA5800/2.1 amplifier features a built-in remote turn-on system that will automatically turn on the amplifier when another devices in the system are switched on. To activate this system, this amplifier must be used in conjunction with a Harman Kardon PT2500, other compatible Harman Kardon products or other approved devices.

NOTE: Before making any connections to remote trigger outlets, it is critical that both the PA5800/2.1 and the triggering device be turned off. For additional safety, it is best that these connections be made while both products are unplugged from AC power sources.

Remote Turn-On Compatible Harman Kardon Products - Including the PT2500

Connect one end of the accessory cable supplied with the PT2500 to the Remote Amp Trigger in [8] jack on the rear of the PA5800/2.1. Connect the other end to the jack on the PT2500 that carries the same identification.

Remote Turn-On Using External AC-to-DC Converter

If the PA5800/2.1 is not used with a compatible Harman Kardon product, it is still compatible to activate the unit for automatic turn-on.

To control the amplifier in this manner you will need a small UL/CSA approved class 2 AC-to-DC power converter capable of delivering a 6 to 12-volt DC signal. The DC voltage should terminate in a standard 3.5 mm mono miniplug, with the tip of the plug “positive” (+). This type of converter may be obtained as a “Power Adapter” from many electronic retailers. Consult your dealer for further information.

Plug the AC adapter into a switched outlet that will be activated when you wish to have the amplifier turn on. This may be the switched outlet at the rear of an AV receiver or other audio equipment, an AC outlet that is part of a current sensing control unit activated by a preamp or surround processor or a switched AC wall outlet.

Connect the 3.5mm miniplug from the power converter to the Remote Amp Trigger in  jack on the rear of the PA5800/2.1.

Audio System Connections

As a general rule, avoid running any input signal or speaker wire connections next to or parallel with AC power cords. This may cause undesired hum or other interference that will greatly degrade signal performance.

When making connections with RCA-type plugs on interconnect cables, make certain to gently but firmly insert the plugs into the jacks on the rear of the PA5800/2.1. Loose connections can cause intermittent sound and may damage your speakers.

Connect the outputs of the PT2500 or your surround processor to the audio inputs of the PA5800/2.1 . To simplify installation, it is best to follow the markings on the rear panel by connecting the Front Right output of the PT2500 to the Front Right input on the PA5800/2.1, following the same pattern for each channel.

Important Note: The PA5800/2.1 is not designed for use in Bridged configuration. Do not connect the same input or speaker to more than one channel.

To ensure that the high-quality signals produced by the PA5800/2.1 are carried to your speakers without loss of clarity or resolution, we recommend that you use high-quality speaker cable. Many brands of cable are available and the choice of cable may be influenced by the distance between your speakers and your amplifier, the type of speakers you use, personal preferences and other factors. Your dealer or installer is a valuable resource to consult in selecting a proper cable for connections between your amplifier and speakers.

Regardless of the brand or type of cable selected, we recommend that you use a cable construction of fine, multi strand copper with a gauge of 14 or smaller. When specifying cable, remember that the lower the number, the thicker the cable.

Cable with a gauge of 16 may be used for short runs of less than ten feet. We do not recommend the use of cables with an AWG equivalent of 18 or higher due to the power loss and degradation in performance that will occur.

Cables that run inside walls should have the appropriate markings to indicate listing with UL ("CL-2/CL-3"), CSA ("FT-4") or appropriate safety agency standards that may require in your area. Questions about running cables inside walls should be referred to your installer or a licensed electrical contractor who is familiar with the NEC and/or the applicable building or electrical code in your area.

Connections to Speakers

The final step of the installation process is to connect the amplifier to your speaker using high-quality cable. A pair of binding posts is provided for each channels output. These posts will accept bare wire or banana-type plugs.

Note that one conductor of the speaker cable will have no markings or an indication of "-" for negative polarity, and the other will have a red line, brand-names markings, a colored thread or some other positive-polarity indication.

The wire with the positive indication should be connected to the red terminals on both the PA5800/2.1 and your speakers. The negative wire should be connected to the black terminal on the PA5800/2.1 and the speakers.

If bare wire is used for connections, strip approximately $\frac{3}{4}$ " (20mm) of insulation from the end of each wire and carefully twist the strands of each conductor together. Be careful not to cut the individual strands or twist them off; for optimal performance, all strands must be used.

Next loosen the knobs of the speaker output terminals far enough so that the cap moves back on its threads past the U-shaped groove at the back end of the terminal. Making certain that you observe polarity by connecting the negative (-) wire to the black terminal and the positive(+) wire to the red terminal, pass the exposed wire through from the top of the slot until the wire is visible from the bottom end. Holding the wire in place, twist the cap back so that the connection is secured. Do not overtighten or use tools, as this may damage the plastic terminal cap or break the delicate wire strands and decrease system performance.

Important Note: When making speaker wire connections, be certain that none of the strands from one lead touch any other lead. This will cause a short circuit and may damage your amplifier or speakers. Damage from short circuits caused in this manner is not covered by the product warranty.

Connections may also be made using standard 4mm OD banana plugs. Before using a banana-type jack, make certain that the plastic screw caps on the PA5800/2.1 are firmly tightened by turning them clockwise until they are snug against the chassis. This will ensure that the maximum surface area of the plug is in contact with the jack. Once the wire has been attached to the banana plug following the plug manufacture's instructions, simply insert the banana plug into the hole provided on the rear of the colored screw caps on the terminal posts. Be certain to observe proper polarity.

Finally, run the cables to the speaker locations. It is highly recommended that the length of cable connecting any pair of speakers be identical. For example, make certain that the cable length connecting left and right front or left and right rear (surround) speaker is identical, even though one

speaker may be physically closer to the amplifier than the other. Do not coil any excess cable, as this may become an inductor that creates frequency response variations in your system.

Connect the wire to the speaker, again being certain to observe proper polarity. Remember to connect the negative or black wire to the matching terminal on the speaker. Similarly, the positive or red wire should be connected to the like terminal on the speaker.

NOTE: While most speaker manufacturers adhere to an industry standard of using black terminals for negative and red for positive, some manufacturers may not adhere to this configuration. To ensure properly phased connections and optimal performance, consult the identification plate on your speaker terminals, of the speaker's manual to verify polarity. If you do not know the polarity of your speaker, ask your dealer or installer for advice before proceeding, or consult the speaker's manufacturer.

OPERATION

The PA5800/2.1 may be operated in either a manual or automatic mode. If the unit is being used in a stand-alone operation you should follow the instructions below for Manual Operation. When the PA5800/2.1 is connected to another compatible device such as the Signature 2.0 or PT2500 tuner, follow the instructions for Automatic Operation.

Make sure the power switch is in the off position before plugging in the AC power cord. After all the connections have been made to the amplifier's input jacks and speaker terminals, connect the power cord to an AC outlet. Turn on your source component and receiver/processor first; start with a low volume level to protect your speakers.

Manual Operation

The LED indicator should be glowing red if the unit is plugged in. Press the front panel switch to turn the unit on.

PA5800 - The indicator surrounding the power switch will turn green after a brief pause.

Signature 2.1 - The indicator will flash green briefly, and then go out; the front panel will then illuminate to blue.

To turn the unit off, press the power switch again. The LED indicator will return to red.

Automatic Operation

Before proceeding, make certain the connection between the Signature 2.0, PT2500, or other trigger source has been connected properly to the unit following the previous directions. At this point the trigger source should be off.

After all cables are connected and the PA5800/2.1 is plugged in, the LED Indicator should be glowing red. Press the power switch and the indicator will turn amber indicating the unit is in the standby mode and ready to turn on when it receives a signal from the triggering device. Finally, turn on your Signature 2.0, PT2500, or other trigger source to turn the PA5800/2.1 on.

PA5800 - The indicator surrounding the power switch will turn green after a brief pause.

Signature 2.1 - The indicator will flash green briefly, and then go out; the front panel will then illuminate to blue.

At the conclusion of your listening session, there is no need to turn the PA5800/2.1 off manually. When the Signature 2.0, PT2500, or other trigger source is turned off, the PA5800/2.1 will return to the standby mode.

Important Note: If you will not be using your audio system for an extended period of time, such as a vacation, we recommend turning the PA5800/2.1 off using the power switch.

IDLE CURRENT ADJUSTMENT PA5800/Signature 2.1

Locate test points:

PA5800 - P75A, P75B, P75C, P75D, P75E

Signature 2.1 - P2, P4, P6, P8, P10

These are 2 pin female molex connectors (5 total, 1 per channel) on the MAIN AMPLIFIER PCB.

Attach a DC voltmeter (set to a low range) to these points. This is best accomplished by making up a "test plug" using a male molex connector that fits into the one in the unit, with wires attached, for connection to the voltmeter. An alternative method is to use two "mini-grabbers" to attach to

the two outer pins on each connection. Warning: Do not accidentally short the two points together with a meter probe during adjustment.

Adjustment Points:

PA5800 - R70A, R70B, R70C, R70D, R70E

Signature 2.1 - R22, R55, R103, R151, R199

Adjust to 25mv across test points, one channel at a time until all channels comply.

PROTECT MODE

Input/Output Protection

Under some conditions, such as a shorted speaker wire, DC voltage on an input connection or thermal overload, the amplifier will place itself in a “protect mode” to prevent damage to the amplifier.

Signature 2.1

When this happens, the LED Power Indicator will flash and alternate between red and amber.

PA5800

When this happens, the LED power indicator will flash amber.

When this occurs, **IMMEDIATELY** turn off the unit using the power switch and correct the problem. Then turn the unit back on. If the unit continues to go into protect mode, contact your dealer or installer for assistance.

TROUBLE SHOOTING

The items listed below are a brief guide to minor problems that may arise with audio equipment such as the PA5800/2.1. Before taking a unit in for service, you should check to see if any of these hints solve the problem. If these solutions do not rectify the problem or if the problem recurs, contact your dealer or an authorized Harman kardon service depot for assistance.

PROBLEM	DIAGNOSIS	TROUBLESHOOTING HINTS
Amplifier will not turn on.	<ul style="list-style-type: none"> ■ Power Switch turned off. (No Power Light LED) ■ Remote trigger cable not properly connected. 	<ul style="list-style-type: none"> ■ Turn on Power Switch ■ Verify connection of trigger cable at both ends
Amplifier turns on, but no audio from one or more channels	<ul style="list-style-type: none"> ■ Inputs not connected to proper jack. ■ Speakers not connected Properly. ■ Improper settings or output levels from processor or controller. 	<ul style="list-style-type: none"> ■ Check input connections. ■ Check speaker connections. ■ Check the settings on your preamp, processor or controller.
Audio plays, then cuts off.	<ul style="list-style-type: none"> ■ Signature 2.1 - amplifier shorted (LED flashes amber and red). ■ PA5800 - amplifier shorted (LED flashes amber) 	<ul style="list-style-type: none"> ■ Check speaker connections for Short circuit.
Hum	<ul style="list-style-type: none"> ■ Signature 2.1 - Objectionable hum (coming from unit itself, not from loudspeakers). 	<ul style="list-style-type: none"> ■ Certain types of half-power light dimmers on the same AC circuit may cause this, or any other electronic device That introduces DC into the AC circuit the unit is plugged into. Remove offending device; or plug the unit into a different AC circuit. Otherwise: If upon internal inspection the POWER SWITCH PCB does not have the designator HA206-0003-C printed on it (near the relays), order this board by part number HA206-0003-C from Harman.

PA5800 MECHANICAL EXPLODED VIEW

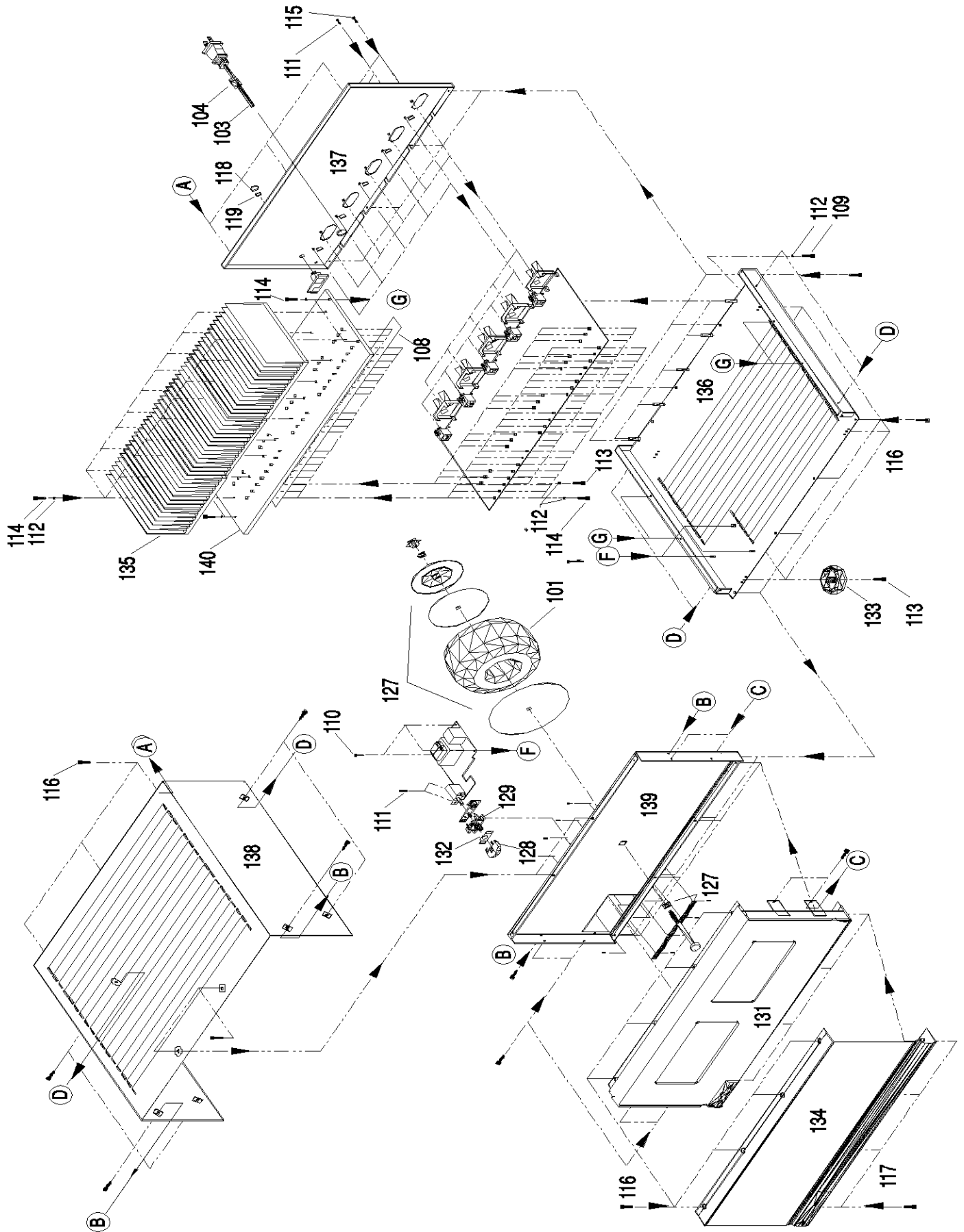

PA5800 MECHANICAL PARTS LIST

Ref.#	Part #	Description	Qty			
					115-7008-0	WASHER, 8MM, BELLEVILLE, SPRING STEEL 1
101	A080-0007-B	TRANSFORMER PA5800, 120V, UL SPECS	1			
	A092-0061-0	FASTON, F, V, .250X.032X.260, 14-16GA	2		153-0100-0	SAFETY LABEL (RISK OF FIRE) NORMAL BLOW FU 1
103	A095-0021-0	CORD, 2X16GA, FLAT, 8FT, DOM	1		202-0006-B	CABLE ASSY. 1
	100-0003-0	STRAIN RELIEF, 2X16GA, SR-5KN-4	1	128	HA090-0001-A	POWER SWITCH BUTTON 1
	100-0018-0	WIRE SADDLE ADH. BASE	2		HA090-0002-A	LIGHT PIPE INDICATOR 1
	100-0033-0	CABLE TIE - PLT 1M-M, SMALL	7		HA090-0003-A	SWITCH SPRING 1
	100-0126-0	HOLDER, CABLE TIE .75" SQUARE ADH.	3		HA090-0004-A	PLASTIC FRONT BODY SUB PANEL 1
	105-0009-0	INSULATOR TAPE, 3/4"x7 MIL ADH. BACK			HA090-0005-A	LIGHT SHIELD 1
	111-0101-0	BOLT, 4-40, 5/8, PHP, CAD.	5	133	HA101-0000-A	FOOT 4
	111-2041-0	BOLT, 4-40, 1/4, PHP, INT STAR WASHER, ZINC	3	134	HA132-0001-A	FRONT PANEL ALUMINUM 1
	111-3080-0	SCREW, 4AB, 1/2, PHP, B.Z.	7	135	HA132-0002-A	HEAT SINK 3
	111-7011-0	WASHER, #4, SPLIT	62	136	HA132-0003-B	FAB, CHASSIS, BASE 1
	111-8061-0	TR-BOLTM 4-40, 3/8, PHP, CAD	19	137	HA132-0004-A	REAR PANEL 1
	111-8081-0	TE-BOLT, 4-40, 1/2, PHP, CAD	42	138	HA132-0005-B	FAB, TOP COVER 1
	112-3080-0	SCREW, 6AB, 1/2, PHP, B.Z.	5	139	HA132-0006-B	FAB CROSS BRACE 1
	112-8040-0	TR-BOLT, 6-32, 1/4, PHP, B.Z.	27	140	HA132-0007-A	SINK PLATE 1
	112-8050-0	TR-BOLT, 6-32, 5/16, PHP, BO	4		HA206-0001-B	POWER SWITCH BOARD 1
	115-6003-1	NUT, 8MM, HEX, CAD, B.O.	1			

PA5800 PACKING EXPLODED VIEW

Ref.#	Part #	Description	Qty
40	150-0089-0	BAG POLY 24"x30"x3 mil with vent holes	1
41	150-0103-0	BAG POLY 9"x12"x2 mil CLEAR	1
42	HA160-0000-A	OWNER'S MANUAL	1
43	HA160-0001-A	WARRANTY SHEET	1
44	HA160-0002-A	CUSTOMER CARD	1
45	160-0005-0	GROUNDING SAFETY SHEET	1
46	HA151-0001-A	FOAM PACK CORNERS (4 TOP/4BOTTOM 8 PER SET)	8
47	HA150-0000-A	CARTON	1

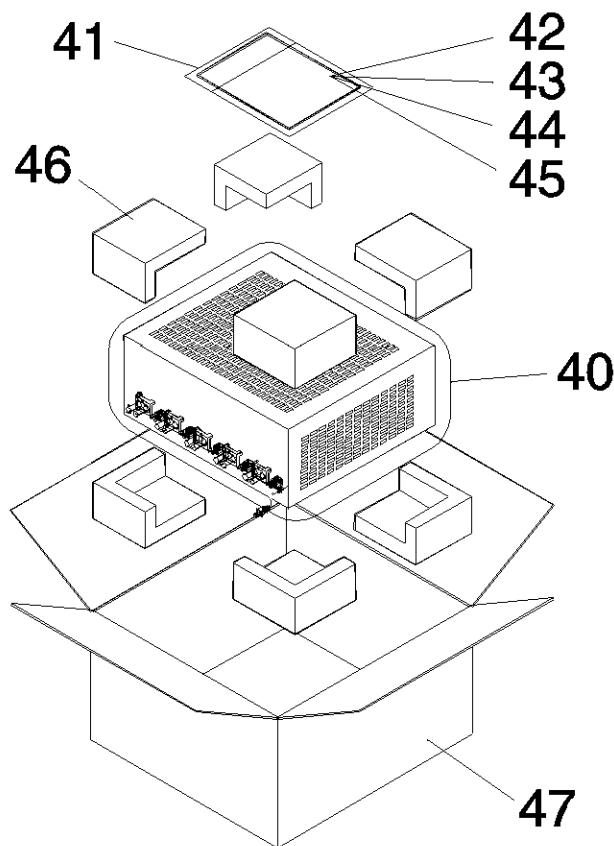

Signature 2.1 MECHANICAL EXPLODED VIEW

REF. NO.	DESCRIPTION & PART NO.	QTY
1	BOLT 4-40 5/16 PHP CAP 111-0051-0	4
2	BOLT 4-40 5/8 PHP CAD 111-0101-0	18
3	SCREW #4S 1/2 PHP B.Z. 111-3060-0	5
4	TR-BOLT 4-40 3/8 PHP CAD 111-9051-0	43
5	TR-BOLT 4-40 1/2 PHP CAD 111-9051-0	30
6	BOLT 6-32 1/4 PHP ZINC 112-0040-0	4

REF. NO.	DESCRIPTION & PART NO.	QTY
7	112-9080-0	5
8	TR-BOLT 6-32 5/16 PHP 80 112-9050-0	27
9	WASHER #4 SPLT 111-7011-0	93
10	WASHER #8 SPLT ZINC 112-7021-0	4
11	STRAIN RELIEF 182, SPT-2, UL, CSA 100-0050-0	12
12	POWER CORD, 2x18-16 GA, SPT-2, UL, CSA 065-0002-0	2

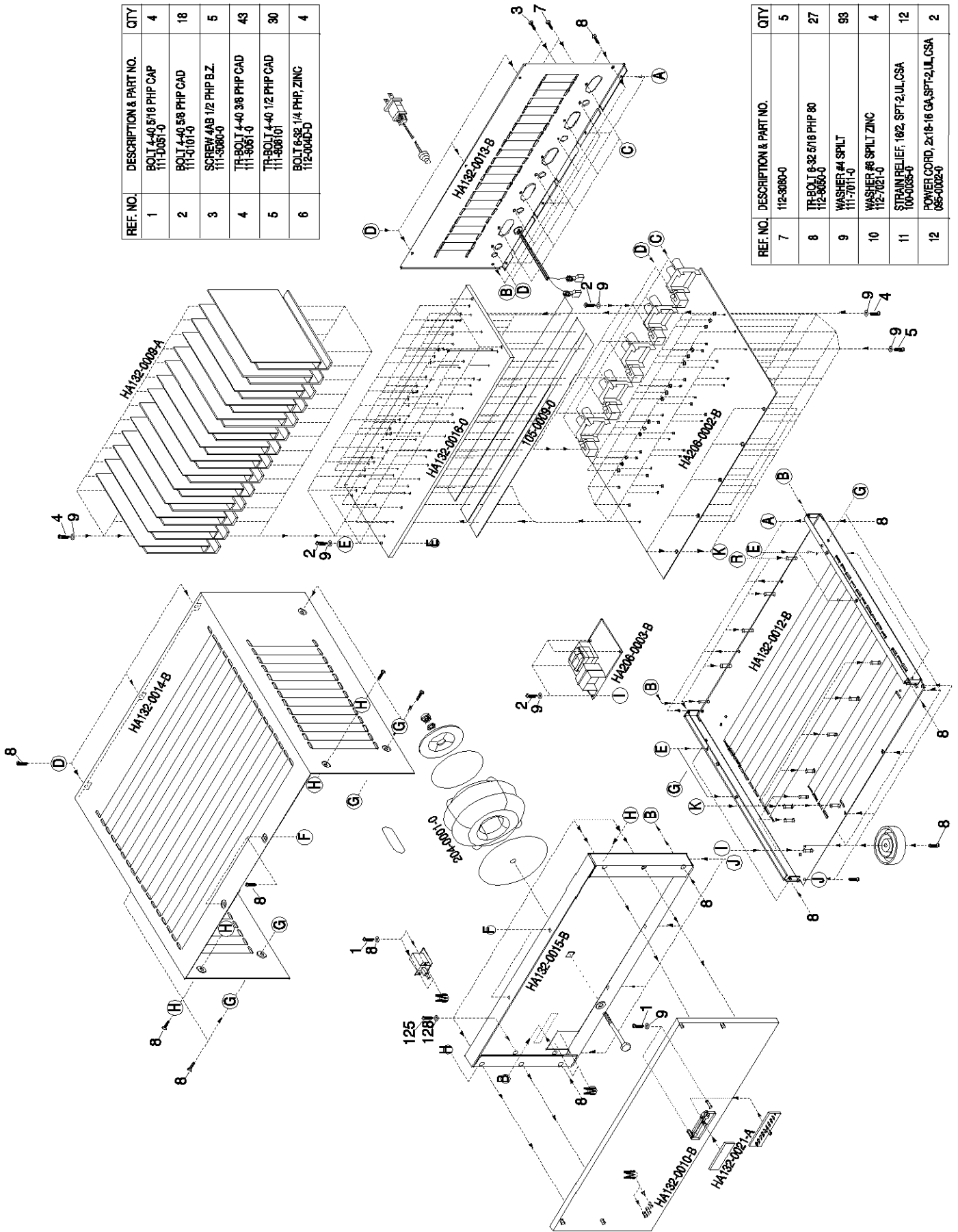

Signature 2.1 MECHANICAL PARTS LIST

Ref.#	Part #	Description	Qty	Ref.#	Part #	Description	Qty
	A080-0010-A	TRANSFORMER SIG 2.1, 120V TO SP	1		153-0100-1	SAFETY LABEL(RISK OF FIRE), FAST F	1
	A080-0011-A	TRANSFORMER SIG 2.1, 230V	1		HA132-0009-A	SIG 2.1, FIN PLATE	28
	A091-0007-0	FUSE, 5MM, 0.5A, 125V, FAST, UL, CSA	1		120-0002-1	ALUM .080, 5052-H32, 6.00X5.15 +/-	1
	A091-0008-0	FUSE, 5MM, 5A, 125V, FAST, UL, CSA	10		HA132-0010-A	SIG 2.1 FRONT PANEL, FINISHED	1
	A091-0011-0	FUSE, 5MM, 10A, 125V, FAST, UL, CSA	1		HA132-0012-B	SIG 2.1 CHASSIS	1
	A092-0061-0	FASTON, F, V, .250X.032X.260, 14-16GA	1		111-6036-0	NUT, PEM, S-440-1 FOR .040 MIN. THK	4
	A092-0068-0	FASTON, F, V, .187X.020X.205, 14-16GA	1		112-6009-0	STANDOFF, SO-6440-24	14
	A093-2500-0	HSG, 2MMX7, 26GA, IDC	2		120-0019-0	STEEL, 18 GA.EGC .047 48X120 FPR	480
	A095-1002-0	WIRE 26 AWG, BLK, 7 STRAND, UL1061 1	1		HA132-0013-B	SIG 2.1 REAR PANEL, 120V	1
	A095-0002-0	POWER CORD 16 GAUGE	1		120-0019-0	STEEL, 18 GA.EGC .047 48X120 FPR	198
	100-0011-0	STRAIN RELIEF, SPT-2, UL, CSA	1		HA132-0014-B	SIG 2.1 TOP COVER	1
	100-0035-0	CABLE TIE, BLACK, 4"-18 LB	10		120-0012-0	STEEL, 20 GA.036 EGC 48X120	615
	100-0126-0	HOLDER, CABLE TIE .75" SQUARE, ADHE	5		HA132-0015-B	SIG 2.1 CROSS BRACE	1
	101-0002-0	FOOT BLACK ANODIZED/RUBBER GASKET	4		120-0008-0	STEEL, 16 GA.EGC. 48X120	198
	102-0003-0	BUTTON CAP, LOUDNESS, H/K	1		HA132-0016-B	SIG 2.1 SINK PLATE	1
	105-0009-0	INSULATOR TAPE, 3/4"X7 MIL ADHESIVE	4		129-0003-A	PA5800 SINK PLATE BLANK 16.7000"	1
	111-0051-0	BOLT, 4-40, 5/16, PHP, CAD	2		HA132-0021-A	LOGO, SIGNATURE SERIES, ACRYLIC	1
	111-0061-0	BOLT, 4-40, 3/8, PHP, CAD	2		HA202-0003-A	WIRE ASSY, 26GA, BLK, 9", 2PIN, UL/CSA	1
	111-0101-0	BOLT, 4-40, 5/8, PHP, CAD.	18		A093-1000-0	HSG, 2MMX2, 26GA, IDC	2
	111-3080-0	SCREW, 4AB, 1/2, PHP, B.Z.	5		A095-1002-0	WIRE 26 AWG, BLK, 7 STRAND, UL1061 1	1
	111-7011-0	WASHER, #4, SPLIT	93		HA202-0004-A	WIRE ASSY, 26GA, BLK, 7", 7PIN, UL/CSA	1
	111-8061-0	TR-BOLT, 4-40, 3/8, PHP, CAD	43		A093-2500-0	HSG, 2MMX7, 26GA, IDC	2
	111-8081-0	TR-BOLT, 4-40, 1/2, PHP, CAD	30		A095-1002-0	WIRE 26 AWG, BLK, 7 STRAND, UL1061 1	1
	112-0040-0	BOLT, 6-32, 1/4, PHP, ZINC	4		HA202-0005-A	WIRE ASSY, 26GA, BLK, 18.5", 5PIN, UL/	1
	112-3080-0	SCREW, 6AB, 1/2, PHP, B.Z.	5		A093-1003-0	HSG, 2MMX5, 26GA, IDC	2
	112-7001-0	WASHER, #6, FLAT, CAD	4		A095-1002-0	WIRE 26 AWG, BLK, 7 STRAND, UL1061 1	1
	112-7021-0	WASHER, #6, SPLIT ZINC	4		HA206-0002-B	SIG 2.1 POWER AMP BOARD, 120V	1
	112-8050-0	TR-BOLT, 6-32, 5/16, PHP, BO	27				

Signature 2.1 PACKING EXPLODED VIEW

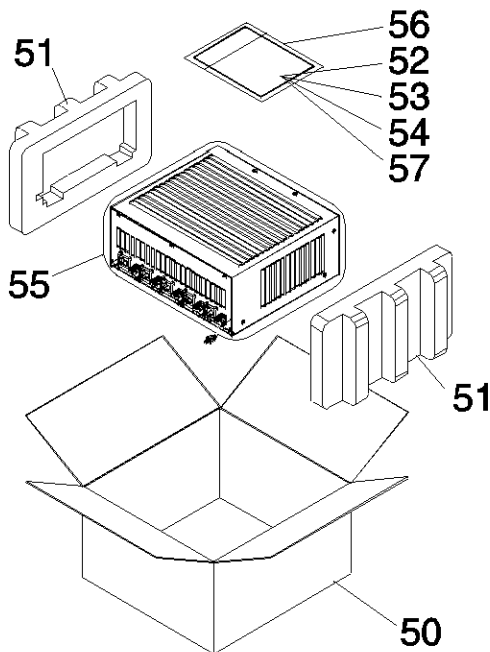

Ref.#	Part #	Description	Qty
50	HA150-0001-A	SIG 2.1 CARTON	1
51	HA151-0002-A	SIG 2.1/1.5 FOAM PACK	1
52	HA160-0001-A	HARMAN WARRANTY SHEET	1
53	HA160-0002-A	HARMAN CUSTOMER CARD	1
54	HA160-0003-A	SIG 2.1 OWNER'S MANUAL	1
55	150-0089-0	BAG POLY 24X30 3 MIL WITH VENT HO	1
56	150-0103-0	BAG, PLOY 9"X12"X2MIL CLEAR	1
57	160-0005-0	GROUNDING SAFETY SHEET	1

PA5800 ELECTRICAL PARTS LIST

Reference #	Part #	Description	Quantity	Reference #	Part #	Description	Quantity
Power Switch/Remote Trigger Board							
Integrated Circuit							
U254	A001-2009-0	LM556CN DUAL TIMER	1	J284	A092-0019-0	JACK, PHONE, 3.5MM, S-TIP, O-SLEV, VERT PC	1
Transistors							
Q218, 225, 226, 240, 245, 251	A010-0012-0	MPSA06 NPN 80V 500MA TO-92	6	P221	A093-0043-0	HDR, 2MMX3, VERT, MALE LOCK	1
Q232, 234	A010-1013-0	MPSA56 PNP 80V 500MA TO-92	2	P237	A093-0151-0	HDR, 2MMX5, VERT, MALE, LOCKING	1
Diodes							
D212, 213, 214, 215	A020-2106-0	1N4004, RECT, 1A, 150V, DO-41	4	P260	A093-0026-0	HDR, .1X3, HORIZ, MALE, SQUARE PIN, TIN	1
D217, 231, 236, 238, 241, 243, 264	A020-1000-0	1N4148, RECT-FAST, 200MA, 100V, 4NS, DO-35	7	P271	A093-0526-0	HDR, .1X3, BOTTOM ENTRY, 093-0026 MATE	1
D260	A020-0050-0	1N751, ZENER, 5V 10%, 400MW, DO-35	1	P280	A093-0044-0	HDR, 2MMX3, HORIZ, MALE LOCK	1
D270	A025-0012-0	LED, RED/GRN, 5MM, 630NM/560NM, 15MCD/15MCD	1	FUSE CLIP	A094-0004-0	FUSE CLIP, 5MM, PC MOUNT	2
Capacitors				POWER AMP BOARD			
C204	A034-7103-0	CAP, CERAMIC DISK, .01 μ F, 10%, X-250V	1	Transistors			
C210, 220, 224, 228, 259, 261	A031-0108-0	CAP, ELEC, RAD, 100 μ F, -10%+50%, 16V	6	Q14A, 14B, 14C, 14D, 14E, 18A, 18B, 18C, 18D, 18E	A010-0010-0	2SC2240, NPN, 120V, 100MA, TO-92	10
C211, 216, 244, 257, 262	A030-2104-0	CAP, CER, AX, .1 μ F, 10%, 50V, X7R	5	Q23A, 23B, 23C, 23D, 23E, 24A, 24B, 24C, 24D, 24E	A010-0012-0	MPSA06, NPN, 80V, 500MA, TO-92	10
C247, 249	A031-2106-0	CAP, ELEC, RAD, 10 μ F, -10%+50%, 50V	2	Q30A, 30B, 30C, 30D, 30E, 37A, 37B, 37C, 37D, 37E	A010-1010-0	2SA970, PNP, 120V, 100MA, TO-92	10
C253, 255	A030-2103-0	CAP, CER, AX, .01 μ F, 10%, 50V, X7R	2	Q46A, 46B, 46C, 46D, 46E, 64A, 64B, 64C, 64D, 64E, 79A, 79B, 79C, 79D, 79E	A010-0001-0	2SC3478, NPN, 180V, 100MA	15
C266	A031-0477-0	CAP, ELEC, RAD, 470 μ F, 20%, 10V	1	Q69A, 69B, 69C, 69D, 69E, 82A, 82B, 82C, 82D, 82E	A010-1002-0	2SA1376, PNP, 180V, 100MA, TO-92	10
Resistors							
R222, 223, 233, 235, 239, 281, 282	A050-1003-0	RES CARBON FILM, 10K Ω , 1/8W, 5%	7	Q88A, 88B, 88C, 88D, 88E, 89A, 89B, 89C, 89D, 89E	A012-0002-0	2SC4793, NPN, 200V, 1.5A, 2-10R1A	10
R227	A050-1002-0	RES, CARBON FILM, 1K Ω , 1/8W, 5%	1	Q91A, 91B, 91C, 91D, 91E	A012-1002-0	2SA1837, PNP, 200V, 1.5A, 2-110R1A	5
R229, 248	A051-2701-0	RES, CARBON FILM, 270 Ω , 1/4W, 5%	2	Q99A, 99B, 99C, 99D, 99E	A012-0003-0	2SC5242, NPN, 230V, 15A, 2-16C1A	10
R230, 246, 256	A050-1004-0	RES, CARBON FILM, 100K Ω , 1/8W, 5%	3	Q100A, 100B, 100C, 100D, 100E, 101A, 101B, 101C, 101D, 101E	A012-1003-0	2SA1962, PNP, 230V, 15A, 2-16C1A	10
R242	A050-3302-0	RES, CARBON FILM, 3.3K Ω , 1/8W, 5%	1	Q121	A010-1013-0	MPSA56, PNP, 80V, 500MA, TO-92	1
R250	A050-4702-0	RES, CARBON FILM, 4.7K Ω , 1/8W, 5%	1	Diodes			
R252	A050-4703-0	RES, CARBON FILM, 47K Ω , 1/8W, 5%	1	D31A-E, D33A-E, D41A-E, D80A-E, D81A-E	A020-1000-0	1N4148, REST-FAST, 200MA, 100V, 4NS, DO-35	25
R258	A051-4703-0	RES, CARBON FILM, 47K Ω , 1/4W, 5%	1	D90A, 90B, 90C, 90D, 90E, 92A, 92B, 92C, 92D, 92E	A020-2106-0	1N4004, RECT, 1A, 150V, DO-41	10
R263, 265	A050-2205-0	RES CARBON FILM, 2.2M Ω , 1/8W, 5%	2	BR53A, 53B, 53C, 53D, 53E	A023-0004-0	BRIDGE, 8A, 200V, VERT, PC	5
R283	A050-1001-0	RES, CARBON FILM, 100 Ω , 1/8W/ 5%	1				
Miscellaneous							
T209	A080-0006-A	TRANSFORMER STANDBY, 120/10@.09A, PCB	1				
K206	A084-0002-0	RELAY, 12VDC, 1A, 15AMP/125VAC, TV-8, PCB	1				
S219	A090-007-0	SWITCH, 8A/128A, 250V, PP, PCB	1				
F203	A091-0023-0	FUSE, 1/4, 10A, 250V, FAST, CERAMIC ACG	1				
F208	A091-0000-0	FUSE, 5 x 20mm, .5A, 250V, SLO BLO	1				
	HA206-0001-B	Loaded PA5800 Power Switch Board	1				

Reference #	Part #	Description	Quantity	Reference #	Part #	Description	Quantity
Capacitors				R54A, 54B, 54C, 54D, 54E, 55A, 55B, 55C, 55D, 55E, 93A, 93B, 93C, 93D, 93E, 96A, 96B, 96C, 96D, 96E	A050-0101-0	RES, CARBON FILM, 10Ω, 1/8W, 5%	20
C6A-E, C7A-E, C12A-E	A030-2271-0	CAP, CER AXIAL, 2700pf, 10%, 50V, NPO	15	R60A, 60B, 60C, 60D, 60E, 61A, 61B, 61C, 61D, 61E, 83A, 83B, 83C, 83D, 83E, 84A, 84B, 84C, 84D, 84E	A056-330-1	RES, WIRE WOUND, .33KΩ, 3W, 5%	20
C9A, 9B, 9C, 9D, 9E	A032-4104-0	CAP, PE, .1μF, 10%, 100V	15	R62A-E, R66A-E	A050-2203-0	RES, CARBON FILM, 22KΩ, 1/8W, 5%	10
C17A-E, C49A-E, C50A-E	A031-3476-0	CAP, ELEC, RAD, 47μF, 20%, 63V	15	R65A-E	A050-2202-0	RES, CARBON FILM, 2.2KΩ, 1/8W, 5%	5
C22A-E	A031-0477-0	CAP, ELEC, RAD, 470μF, 20%, 10V	5	R70A, 70B, 70C, 70D, 70E	A070-0520-0	POT, 500Ω TRIM, .375 ROUND, SLOT, .5W	5
C26A, 26B, 26C, 26D, 26E, 27A, 27B, 27C, 27D, 27E	A031-2828-0	CAP, ELEC, RAD, 8200μF, 20%, 50V	10	R78A-E	A050-1202-0	RES, CARBON FILM, 1.2KΩ, 1/8W, 5%	5
C32A, 34B, 34C, 34D, 34E, 38A, 38B, 38C, 38D, 38E	A030-2102-0	CAP, CER, AX, .001μF, 10%, 50V, X7R	10	R87A-E, R102A-E, D122	A050-4703-0	RES, CARBON FILM, 47KΩ, 1/8W, 5%	11
C44A, 44B, 44C, 44D, 44E, 71A, 71B, 71C, 71D, 71E	A031-2106-0	CAP, ELEC, RAD, 10μF, -10%+50%, 50V	10	Miscellaneous			
C45A-E	A035-8150-0	CAP, MICA, 15PF, 5%, 500V	5	L94A, 94B, 94C, 94D, 94E, 97A, 97B, 97C, 97D, 97E	A081-0057-0	INDUCTOR, 2UH, 7A, 2743002112 FERRITE BEAD	10
C51A, 51B, 51C, 51D, 51E, 52A, 52B, 52C, 52D, 52E	A030-4104-0	CAP, CER AXIAL, 2700pf, 10%, 100V, X7R	10	FUSE	A091-0019-0	FUSE, 5MM, 5A, 250V, SLB, UL, SEMKO	10
C56A-E, C57A-E, 124	A030-2104-0	CAP, CER, AX, .1μF, 10%, 50V, X7R	11	FUSE CLIP	A094-0004-0	FUSE CLIP, 5MM, PC MOUNT	10
C67A-E	A035-8131-0	CAP, MICA, 130PF, 5%, 500V	5	TH127	A091-1002-0	THRM BRKR 105C +/-5, 0-DIFF, PC	1
Resistors					A091-1003-0	THRM BRKR 100C +/-5, 0-DIFF, PC	1
R2A-E	A050-1004-0	RES, CARBON FILM, 100KΩ, 1/8W, 5%	5	J5A, 5B, 5C, 5D, 5E	A092-0018-0	BINDING POST, X2, H, PC, NI	5
R3A-E	A060-1242-0	RES, METAL FILM, 1.24K, 1/8W, 1%	5	J1A, 1B, 1C, 1D, 1E	A092-0031-0	JACK, RCAX1, H, PC, GOLD, WT	5
R8A, 8B, 8C, 8D, 8E	A055-0510-0	RES, METAL OXIDE, 5.1Ω, 2W, 5%	5	P75A, 75B, 75C, 75D, 75E	A093-0025-0	HDR, .1X2, VERT, MALE, LOCK, GOLD	5
R10A, 10B, 10C, 10D, 10E	A055-0101-0	RES, METAL OXIDE, 10Ω, 2W, 5%	5	P86A, 86B, 86C, 86D, 86E	A093-0080-0	HDR, .156X3, VERT, MALE, LOCK, SQR PINS, TIN	5
R11A, 11B, 11C, 11D, 11E, 43D, 43E	A050-3303-0	RES, CARBON FILM, 33KΩ, 1/8W, 5%	7	P123	A093-0151-0	HDR, 2MMX5, VERT, MALE, LOCKING	1
R13A-E, R16A-E, R20A-E, R72A-E	A050-1002-0	RES, CARBON FILM, 1KΩ, 1/8W, 5%	20	RL47A, 47B, 47C, 47D, 47E	A081-0032-0	INDUCTOR .4 UH WITH 1Ω 2W RESISTOR	5
R21A-E	A050-1801-0	RES, CARBON FILM, 180Ω, 1/8W, 5%	5		HA206-000-C	LOADED PA5800 AMPLIFIER BOARD	1
R28A-E, R35A-E, 68A-E, 77A-E	A050-4701-0	RES, CARBON FILM, 470Ω, 1/8W, 5%	20				
R29A-E, R15A-E, R19A-E, R36A-E, R63A-E, R76A-E, R95A-E	A050-1001-0	RES, CARBON FILM, 100Ω, 1/8W, 5%	35				
R32A, 32B, 32C, 32D, 32E, 73A, 73B, 73C, 73D, 73E, 74A, 74B, 74C, 74D, 74E	A050-5602-0	RES, CARBON FILM, 5.6KΩ, 1/8W, 5%	15				
R42A, 42B, 42C, 42D, 42E, 120	A050-3302-0	RES, CARBON FILM, 33KΩ, 1/8W, 5%	6				
R43A-E	A060-3323-0	RES, METAL FILM, 33.2KΩ, 1/8W, 1%	5				
R48A, 48B, 48C, 48D, 48E, 85A, 85B, 85C, 85D, 85E	A055-6802-0	RES, METAL OXIDE, 6.8K, 2W, 5%	10				

Signature 2.1 ELECTRICAL PARTS LIST

Reference #	Part #	Description	Quantity	Reference #	Part #	Description	Quantity
Power Amplifier Board				C9, 27, 48, 69, 90	A035-8271-0	CAP, PE/MICA, 2700pf, 5%, 100/500V	5
Transistors				C11, 15, 24, 26 45, 47, 66, 68, 87, 89	A031-3476-0	CAP, ELEC, RAD, 47μF, 20%, 63V	10
Q1, 14, 33, 55, 77, 99	A010-1013-0	MPSA56 PNP 80V 500MA TO-92	6	C12, 28, 49, 70, 91	A035-8100-0	CAP, MICA, 10pf, 5%, 500V	5
Q2, 16, 17, 29, 31, 32, 51, 53, 54, 73, 75, 76, 95, 97, 98	A010-0001-0	2SC3478, NPN, 180V, 100MA	15	C13, 14, 34, 37, 55, 56, 76, 79, 97, 100	A030-2102-0	CAP, CER, AX, .001μF, 10%, 50V, X7R	10
Q3, 5, 7, 37, 38, 39, 59, 60, 61, 81, 82, 83, 103, 104, 105	A012-1003-0	2SA1962, PNP, 230V, 15A, 2-16C1A	15	C16, 17, 23, 25, 44, 46, 65, 67, 86, 88	A031-0477-0	CAP, ELEC, RAD, 470μF, 20%, 10V	10
Q4, 6, 8, 40, 41, 42, 62, 63, 64, 84, 85, 86, 106, 107, 108	A012-0003-0	2SC5242, NPN, 230V, 15A, 2-16C1A	15	C18, 29, 50, 71, 92	A032-4104-0	CAP, PE, .1μF, 10%, 100V	5
Q10, 11, 24, 25, 46, 47, 68, 69, 90, 91	A012-0002-0	2SC4793 NPN 200V 1.5A 2-10R1A	10	C19, 20, 21, 35, 36, 38, 56, 57, 59, 77, 78, 80, 98, 99, 101	A030-2271-0	CAP, CER AXIAL, 2700pf, 10%, 50V, NPO	15
Q12, 18, 19, 34, 35, 36, 56, 57, 58, 78, 79, 80, 100, 101, 102	A010-1002-0	2SA1376, PNP, 180V, 100MA, TO-92	15	Resistors			
Q15, 43, 65, 87, 109	A010-1003-0	2SA1380-F, PNP, 200V, 100MA, TO-126	5	R1, 10, 18, 20 21, 44, 47, 71, 72, 76, 77, 78, 79, 119, 120, 124, 125, 126, 127, 167, 168, 172, 173, 174, 175, 215, 216, 220, 221, 222, 223	A050-1001-0	RES, CARBON FILM, 100 OHM, 1/8W, 5%	31
Q13, 44, 66, 88, 110	A010-0003-0	2SC3502-F, NPN, 200V, 100MA, TO-126	5	R2, 3, 11, 24, 28 67, 68, 74, 115, 116, 122, 163, 164, 170, 211, 212, 218	A050-1003-0	RES, CARBON FILM, 10K OHM, 1/8W, 5%	17
Q20, 23, 27, 28, 49, 50, 71, 72, 93, 94	A010-0012-0	MPSA06 NPN 80V 500MA TO-92	10	R4	A050-3302-0	RES, CARBON FILM, 3.3K OHM, 1/8W, 5%	1
Q21, 22, 30, 45, 52, 67, 74, 89, 96, 111	A010-0010-0	2SC2240, NPN, 120V, 100MA, TO-92	10	R5, 7, 12, 43, 61, 62, 73, 109, 110, 121, 157, 158, 169, 205, 206, 217	A050-4703-0	RES, CARBON FILM, 47K OHM, 1/8W, 5%	16
Diodes				R6, 99, 147, 195, 243	A055-0101-0	RES, METAL OXIDE, 10 OHM, 2W, 5%	5
D1, 4, 5, 6, 7, 10, 11, 12, 13, 14, 17, 18, 19, 20, 21, 24, 25, 26, 27, 28, 31, 32, 33, 34, 35	A020-1000-0	1N4148, RECT-FAST, 200MA, 100V, 4NS	25	R8, 9, 100, 101 148, 149, 196, 197, 244, 245	A055-6802-0	RES, METAL OXIDE, 6.8K, 2W, 5%	10
D2, 3, 8, 9, 15, 16, 22, 23, 29, 30	A020-2106-0	1N4004, RECT, 1A, 150V, DO-41	10	R13, 14, 15, 16, 17, 18, 54, 56, 57, 58, 59, 60, 102, 104, 105, 106, 107, 108, 150, 152, 153, 154, 155, 156, 198, 200, 201, 202, 203, 204	A054-220-0	RES, WIRE WOUND, .22 OHM, 1W, %5	30
BR1, 2, 3, 4, 5	A023-0004-0	BRIDGE, 8A, 200V, VERT, PC	5	R23, 27, 45, 48, 50, 64, 83, 84, 85, 86, 112, 131, 132, 133, 134, 160, 179, 180, 181, 182, 208, 227, 228, 229, 230	A050-1002-0	RES, CARBON FILM, 1K OHM, 1/8W, 5%	25
Capacitors				R25, 89, 137, 185, 233	A050-7500-0	RES, CARBON FILM, 75 OHM, 1/8W, 5%	5
C1	A030-2104-0	CAP, CER, AX, .1μF, 10%, 50V, X7R	1				
C2, 3, 30, 31, 51, 52, 72, 73, 93, 94	A031-3129-0	CAP, ELEC, RAD, 12000μF, 20%, 63V	10				
C4, 6, 7, 8, 40, 41, 42, 43, 61, 62, 63, 64, 82, 83, 84, 85, 103, 104, 105, 106	A030-4104-0	CAP, CER AXIAL, .1μF, 10%, 100V, X7R	20				
C5, 10, 32, 33, 53, 54, 74, 75, 95, 96	A031-2106-0	CAP, ELEC, RAD, 10μF, -10%+50%, 50V	10				

Multichannel Power Amplifier

Harman Kardon

PA5800 / SIGNATURE 2.1

Reference #	Part #	Description	Quantity
R26, 75, 123, 171, 219	A050-5602-0	RES, CARBON FILM, 5.6K OHM, 1/8W, 5%	5
R29, 38, 65, 66, 113, 114, 161, 182, 209, 210	A050-0471-0	RES, CARBON FILM, 47 OHM, 1/8W, 5%	10
R30, 63, 111, 159, 207	A050-1202-0	RES, CARBON FILM, 1.2K OHM, 1/8, 5%	5
R31, 32, 33, 34, 35, 36, 90, 91, 92, 93, 94, 95, 138, 139, 140, 141, 142, 143, 186, 187, 188, 189, 190, 191, 234, 235, 236, 237, 238, 239	A050-4701-0	RES, CARBON FILM, 470 OHM, 1/8W, 5%	30
R37, 41, 69, 70, 117, 118, 165, 166, 213, 214	A050-0101-0	RES, CARBON FILM, 10 OHM, 1/8W, 5%	10
R39, 98, 146, 194, 242	A055-0510-0	RES, METAL OXIDE, 5.1 OHM, 2W, 5%	5
R40, 51, 87, 88, 135, 136, 183, 184, 231, 232	A060-3323-0	RES, METAL FILM, 33.2K OHM, 1/8W, 1%	10
R42, 46, 49, 80, 81, 82, 128, 129, 130, 176, 177, 178, 224, 225, 226	A050-1801-0	RES, CARBON FILM, 180 OHM, 1/8, 5%	15
R52, 96, 144, 192, 240	A060-1072-0	RES, METAL FILM, 1.07K OHM, 1/8W, 1%	5
R53, 97, 145, 193, 241	A050-1004-0	RES, CARBON FILM, 100K OHM, 1/8W, 5%	5
R22, 55, 193, 151, 199	A070-0520-0	POT, 500 OHM TRIM, .375 ROUND, SLOT, 5	5

Miscellaneous

F1-10	A091-0008-0	5A Fast-blo GMA 5 x 20mm Fuse	10
TH1	A091-1003-0	BRKR 100C +/-5, 0-DIFF, PC	1
J2, 5, 7, 9, 11	A092-0012-0	BINDING POST, X2, H, PC, GOLD, GALLIEN	5
J3, 4, 6, 8, 10	A092-0032-0	JACK, RCAX1, H, GOLD, WT, SWITCH T/S	5
P2, 4, 6, 8, 10	A093-0025-0	HDR, .1X2, VERT, MALE, LOCK, GOLD	5
P1, 5, 7, 9, 11	A093-0080-0	HDR, .156X3, VERT, MALE, LOCK, SQR PIN	5
RL1, 2, 3, 4, 5	A081-0032-0	INDUCTOR, .4 UH WITH 1 OHM 2W RESI	5
L1, 2, 3, 4, 5, 6, 7, 8, 9, 10	A081-0057-0	INDUCTOR, 2UH, 7A, 2743002112 FERRIT	10
	A093-2005-0	HDR, 2MMX7, VERT, SHROUDED	1
	A094-0004-0	FUSE CLIP, 5MM, P.C. MOUNT	10
	105-0007-0	INSULATOR TUBE	1
	153-0105-0	LABEL, BLANK, .9"X.25"	1
	HA206-0002-B	LOADED 2.1 AMPLIFIER BOARD	1

Power Switch/Indicator Board

Reference #	Part #	Description	Quantity
Integrated Circuits			
U1	A001-0005-0	LM393N, DUAL, 8 PIN DI, COMPARATOR	1
U2	A001-2009-0	LM556CN DUAL TIMER	1
Transistors			
Q2, 3, 4, 7, 8	A010-0012-0	MPSA06 NPN 80V 500MA TO-92	5
Q1, 5, 6	A010-1013-0	MPSA56 80V 500MA TO-92	3
Diodes			
D1, 2, 3, 4, 7	A020-2106-0	1N4004, RECT, 1A, 150V, DO-41	5
D5, 6, 8, 9, 10, 11, 12, 13, 14, 15, 16, 27	A020-1000-0	1N4148, RECT-FAST, 200MA, 100V, 4NS,	12
D17, 18, 19, 20, 21, 22, 23, 24, 25	A025-0030-0	LED, BLUE, T1, .190, 470NM, SMALL	9
D26	A025-0012-0	LED, RED/, 5MM, 630NM/560NM, 15MCD	1
D28	A020-0004-0	1N755A, 7.5V, 500MW, DO-35, ZENER	1
Capacitors			
C1	A034-7103-0	CAP, CERAMIC DISK, .01μF, 10%, X-250V	1
C2, 3, 5, 9, 11	A030-2104-0	CAP, CER, AX, .1μF, 10%, 50V, X7R	5
C4	A031-0108-0	CAP, , RAD, 1000μF, -10%+50%, 16V	1
C6, 7, 8, 12	A031-0107-0	CAP, ELEC, RAD, 100μF, +/-20%, 16V, LOW L	4
C10	A031-0106-1	CAP, , RAD, 10μF, 20%, 25V, NP	1
C13, 14	A030-2103-0	CAP, CER, AX, .01μF, 10%, 50V, X7R	2
Resistor			
R1, 2, 5, 9, 10, 15, 18, 20, 22	A050-1003-0	RES, CARBON FILM, 10K OHM, 1/8W, 5%	9
R3, 4, 6, 19	A050-1004-0	RES, CARBON FILM, 100K OHM, 1/8W, 5%	4
R8, 13	A050-4703-0	RES, CARBON FILM, 47K OHM, 1/8W, 5%	2
R11, 12	A050-4702-0	RES, CARBON FILM, 4.7K OHM, 1/8W, 5%	2
R14	A050-0750-0	RES, CARBON FILM, 7.5 OHM, 1/8W, 5%	1
R16	A051-2202-0	RES, CARBON FILM, 2.2K OHM, 1/4W, 5%	1
R17	A051-1502-0	RES, CARBON FILM, 1.5K OHM, 1/4W, 5%	1
R21	A050-1005-0	RES, CARBON FILM, 1M OHM, 1/8W, 5%	1
Miscellaneous			
F1	A091-0011-0	10A Fast-blo GMA 5 x 20mm FUSE	1
F2	A091-0007-0	.5A Slo-blo GMA 5 x 20mm FUSE	1
	A080-0002-A	TRANSFORMER STANDBY, 120V 10V@.35A1	
J1	A092-0022-0	JACK, PHONE, 3.5MM, H, PC	1
K1, 2	A084-0001-0	RELAY 12VDC, 20A/125VAC, TV-10	2
P1, 3, 4	A092-0010-0	FASTON, M, PC, .25"	3
P2	A092-0024-0	FASTON, M, PC, .187"	1
P5, 6	A093-0051-0	, 2MMX2, VERT, MALE, LOCK	2
S2	A093-0151-0	, 2MMX5, VERT, MALE, LOCKING	1
S1	A093-2005-0	, 2MMX7, VERT, SHROUDED	1
S3	A090-0007-0	SWITCH, 8A/128A, 250V, PP, PCB	1
S4	A093-0049-0	, 2MMX5, HORIZ, MALE, LOCK	1
	A094-0004-0	FUSE CLIP, 5MM, P.C. MOUNT	4
	A022-3001-0	THERMISTOR, 120 OHM, 2AMP, CL-90	1
	HA206-0003-B	LOADED SIG 2.1 POWER SWITCH BOARD	1

PA5800 POWER SWITCH PCB

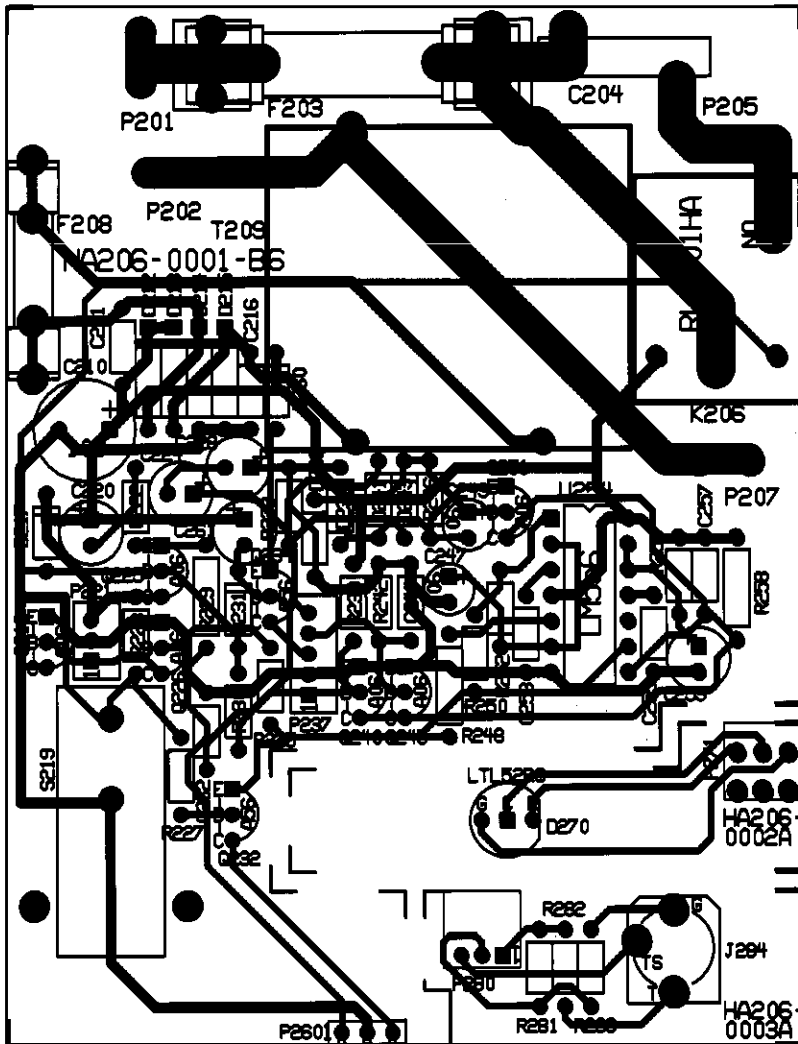

PA5800 POWER SWITCH/
INDICATOR BOARD

HA145-0001-B6

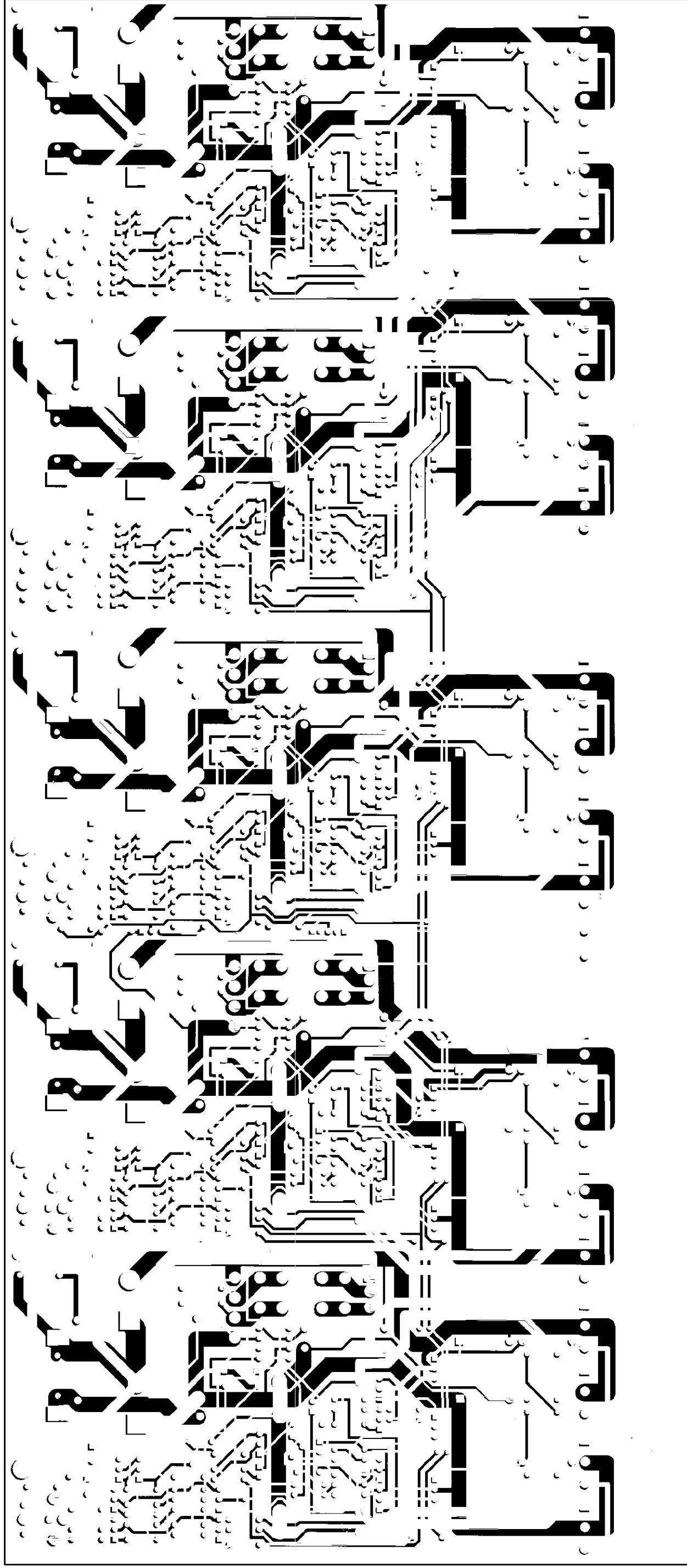

Signature 2.1 POWER SWITCH/INDICATOR PCB Rev B9 & D

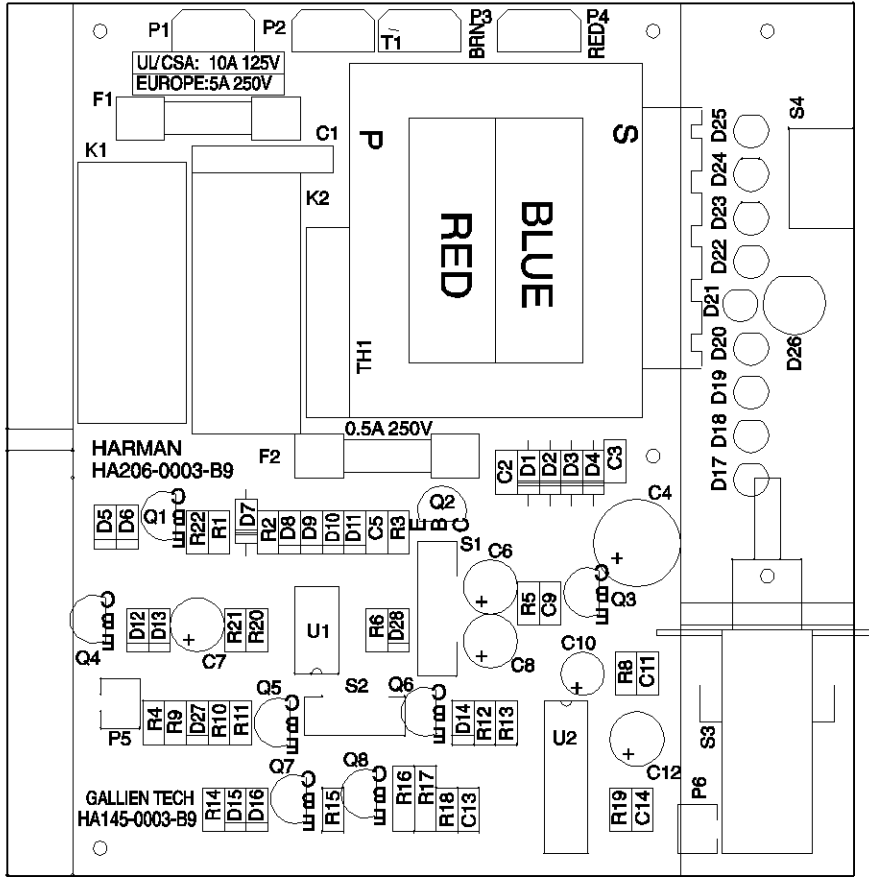

**SIG 2.1 POWER SWITCH/
INDICATOR BOARD
REV. B9**

HA405-0003-B9

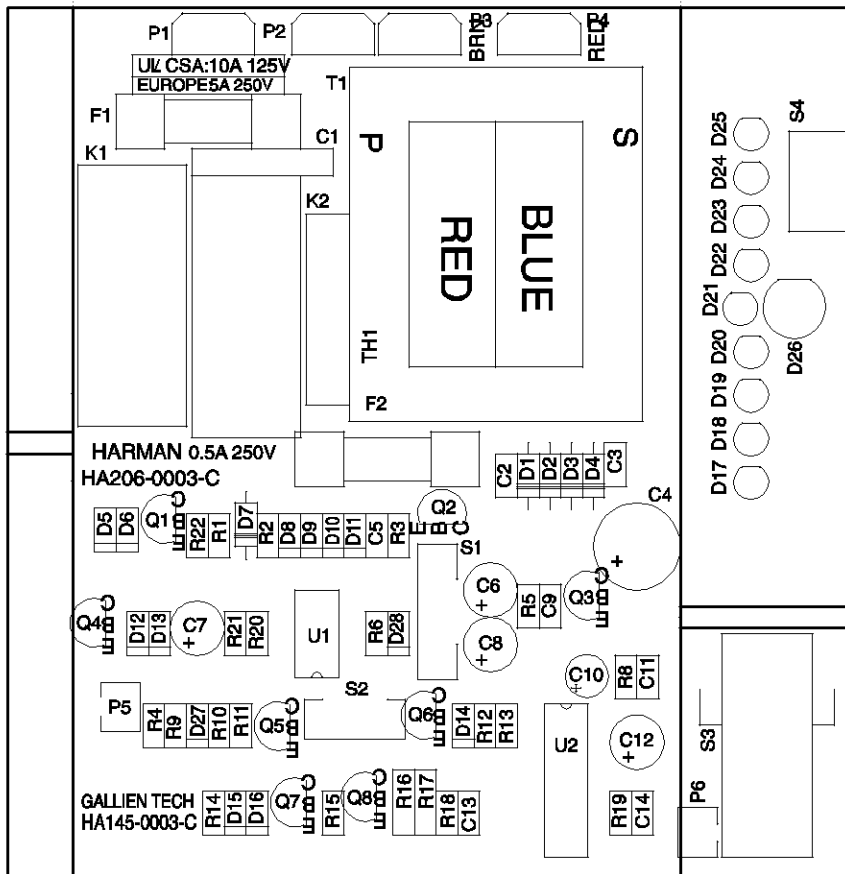

**SIG 2.1 POWER SWITCH/
INDICATOR BOARD
REV. D**

HA145-0003-D

Signature 2.1 POWER AMPLIFIER PCB

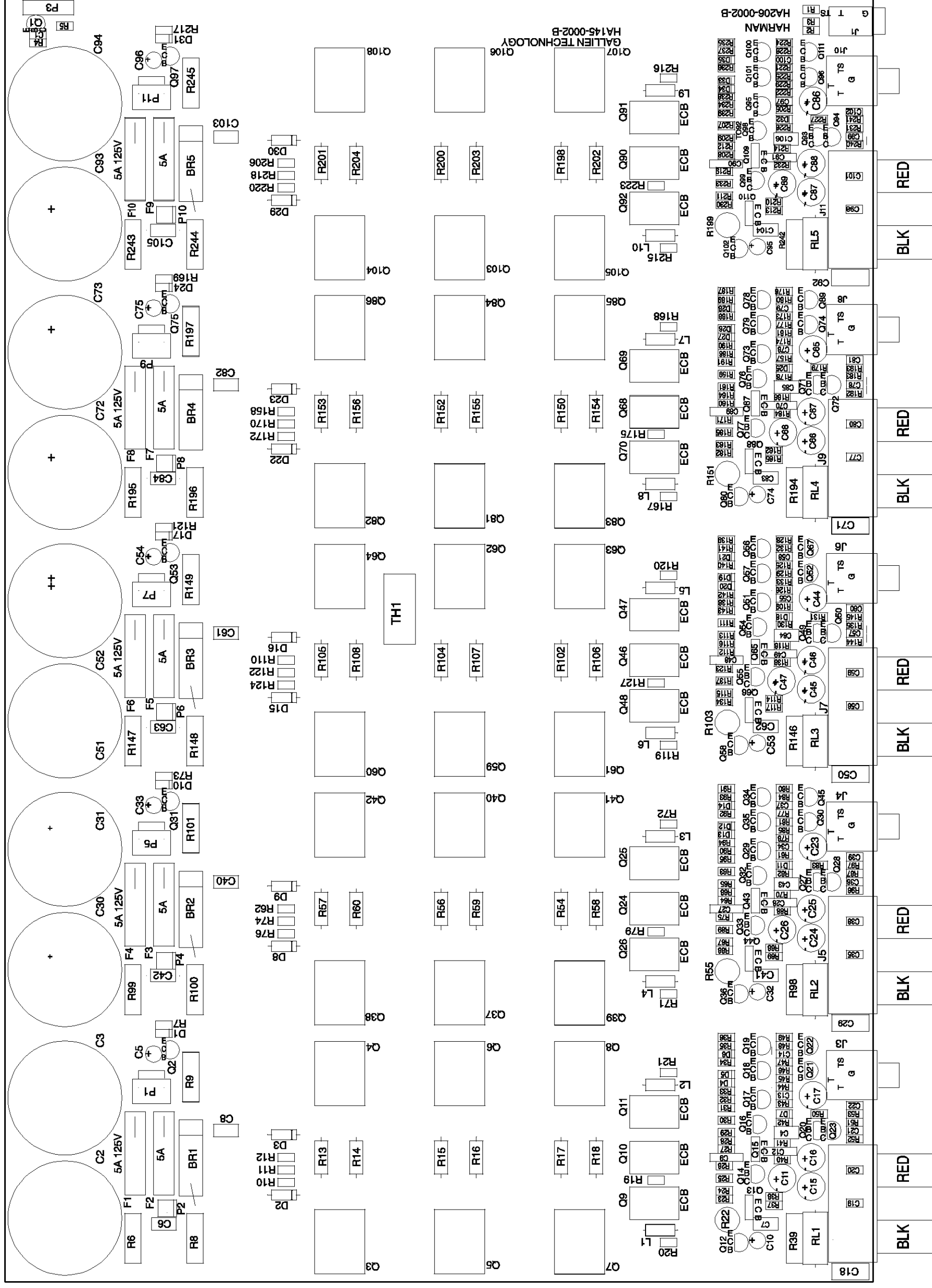

PA5800 (120V) TRANSFORMER WIRING REV B

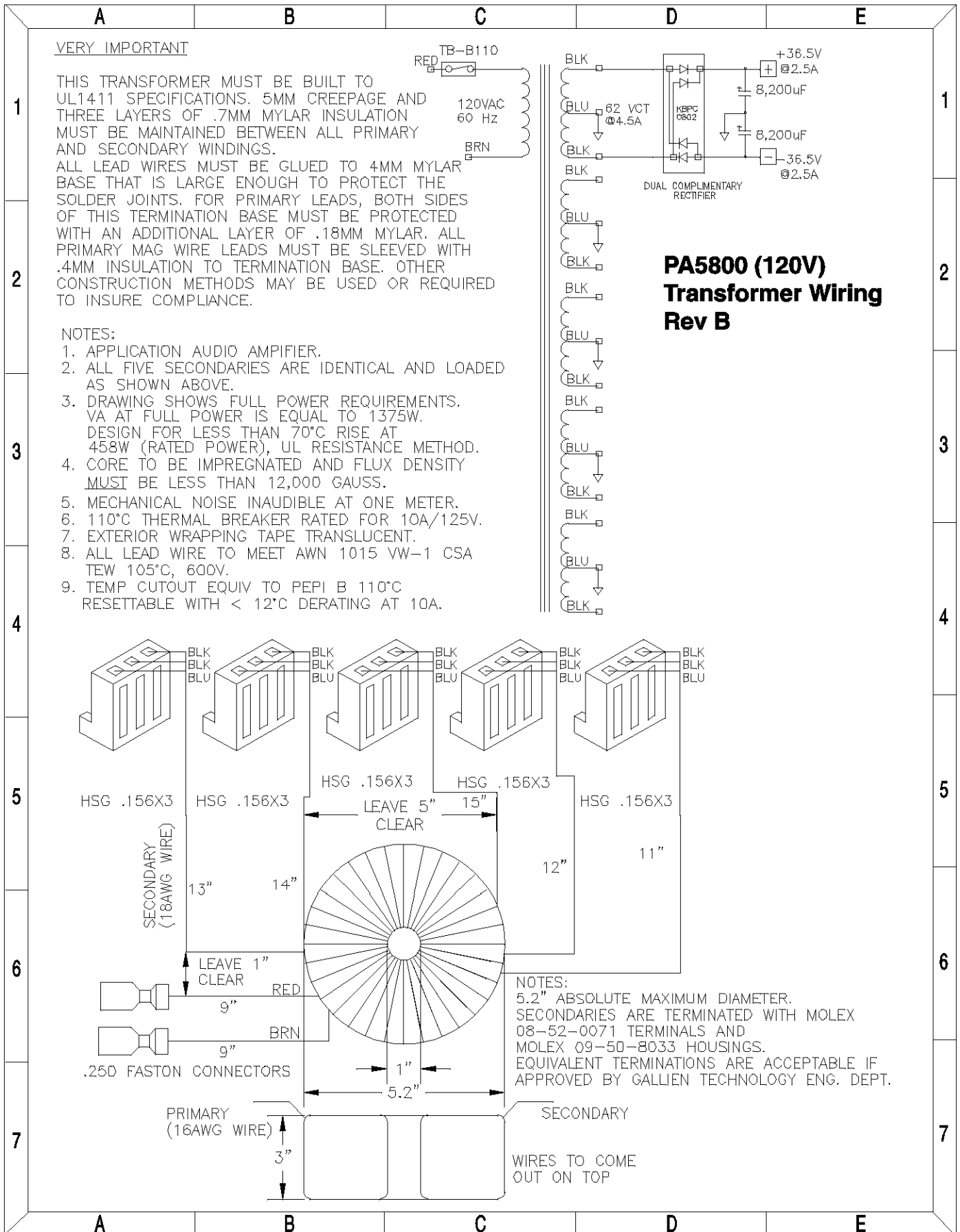

Signature 2.1 (120V) TRANSFORMER WIRING

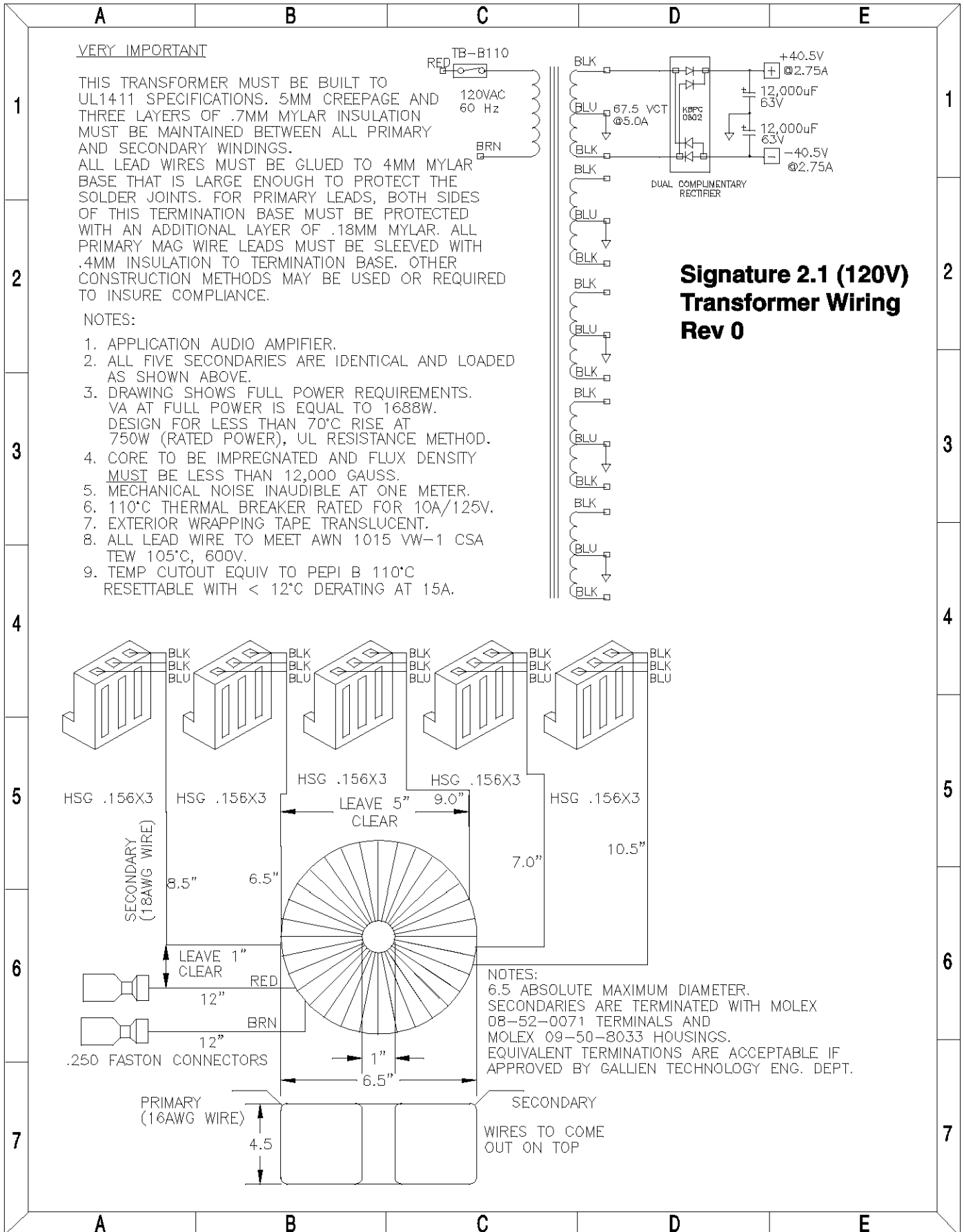

Signature 2.1 (230V) TRANSFORMER WIRING REV 0

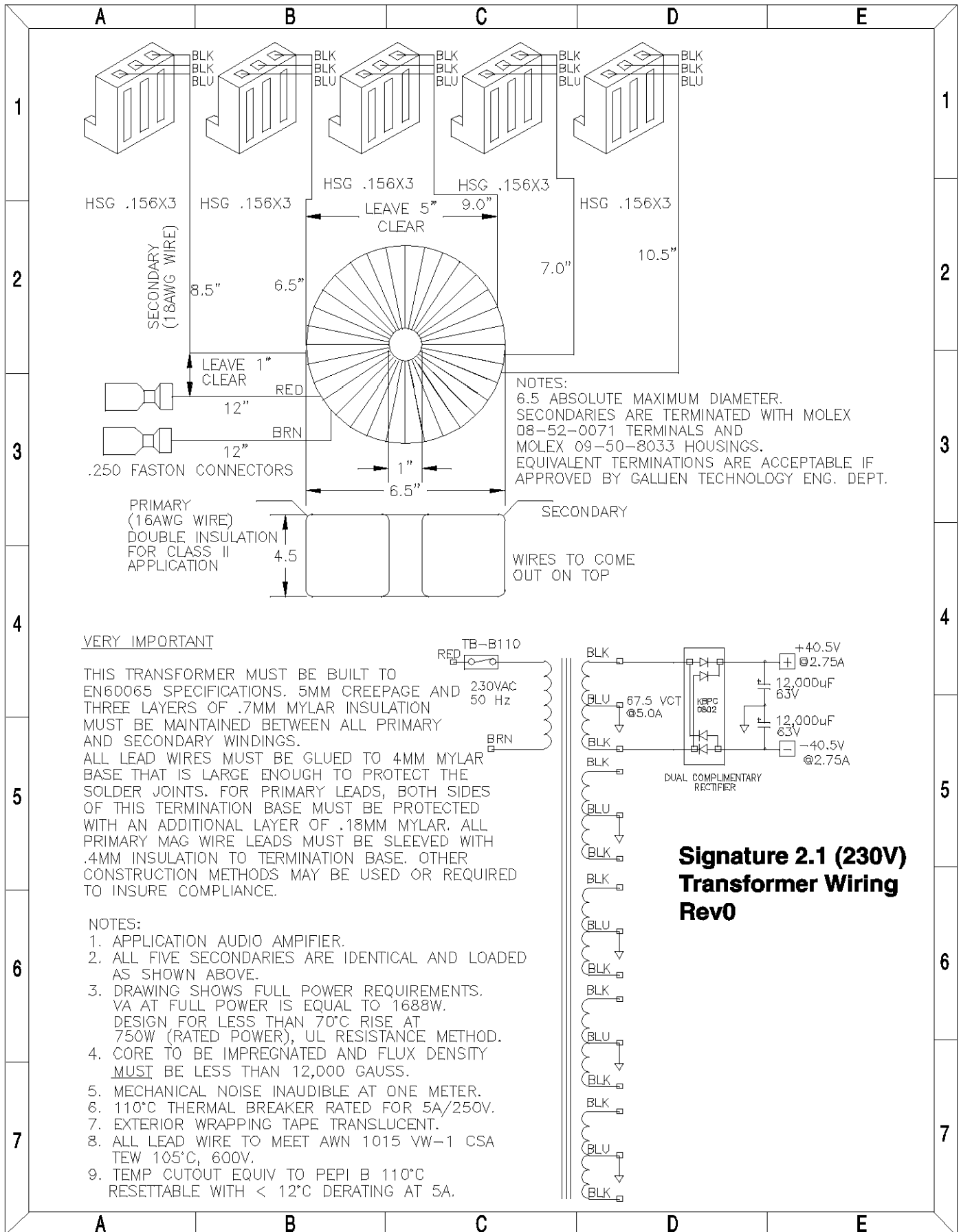

Signature 2.1 (230V) TRANSFORMER WIRING REV B

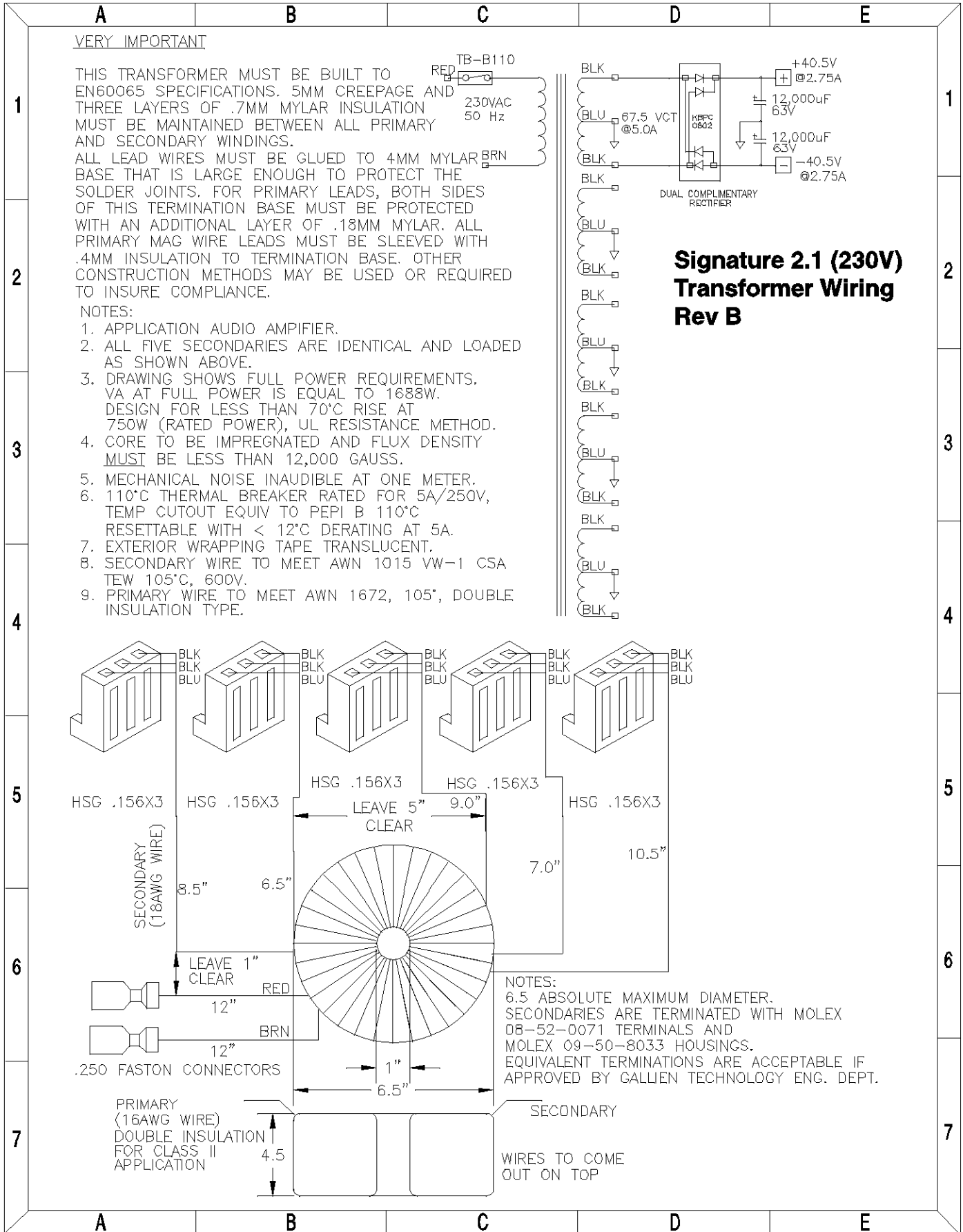

INTEGRATED CIRCUITS

Signature 2.1: U1
LM393N DUAL COMARATOR
A001-0005-0

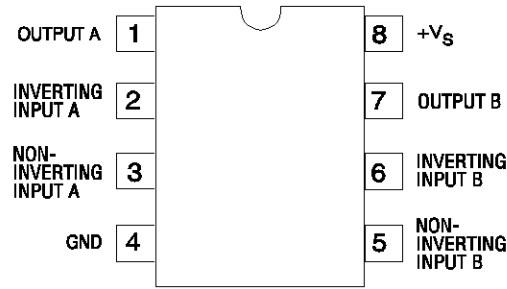

PA5800: U254
Signature 2.1: U2
LM556CN DUAL TIMER
A001-2009-0

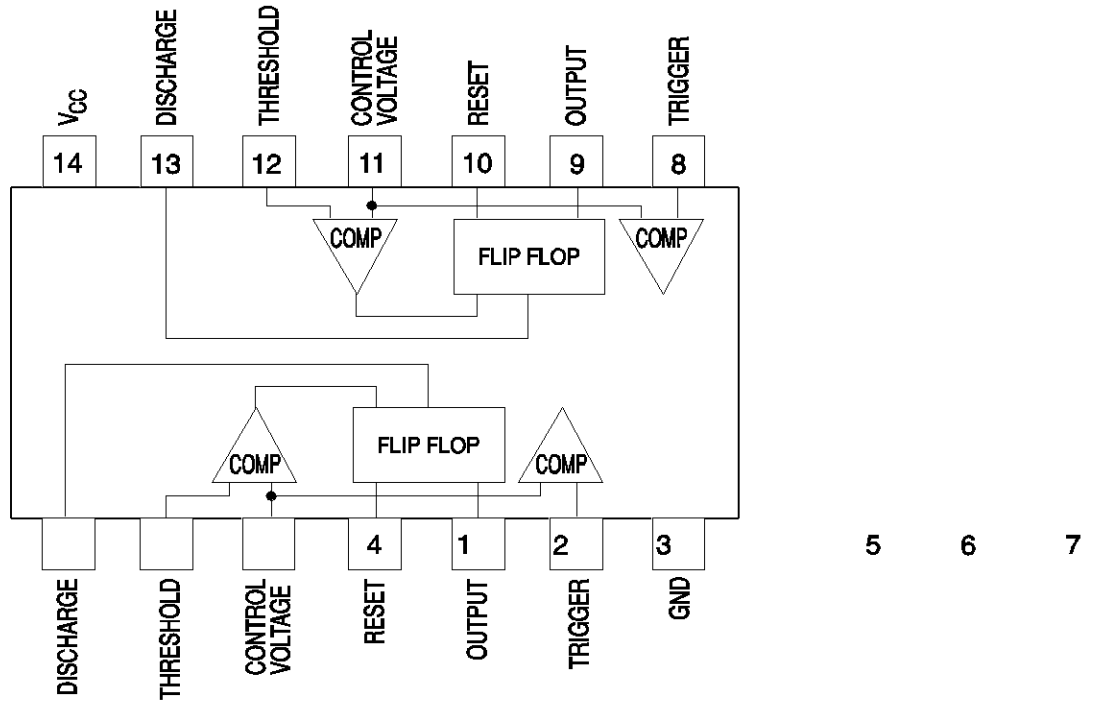

PA5800 POWER AMPLIFIER SCHEMATIC

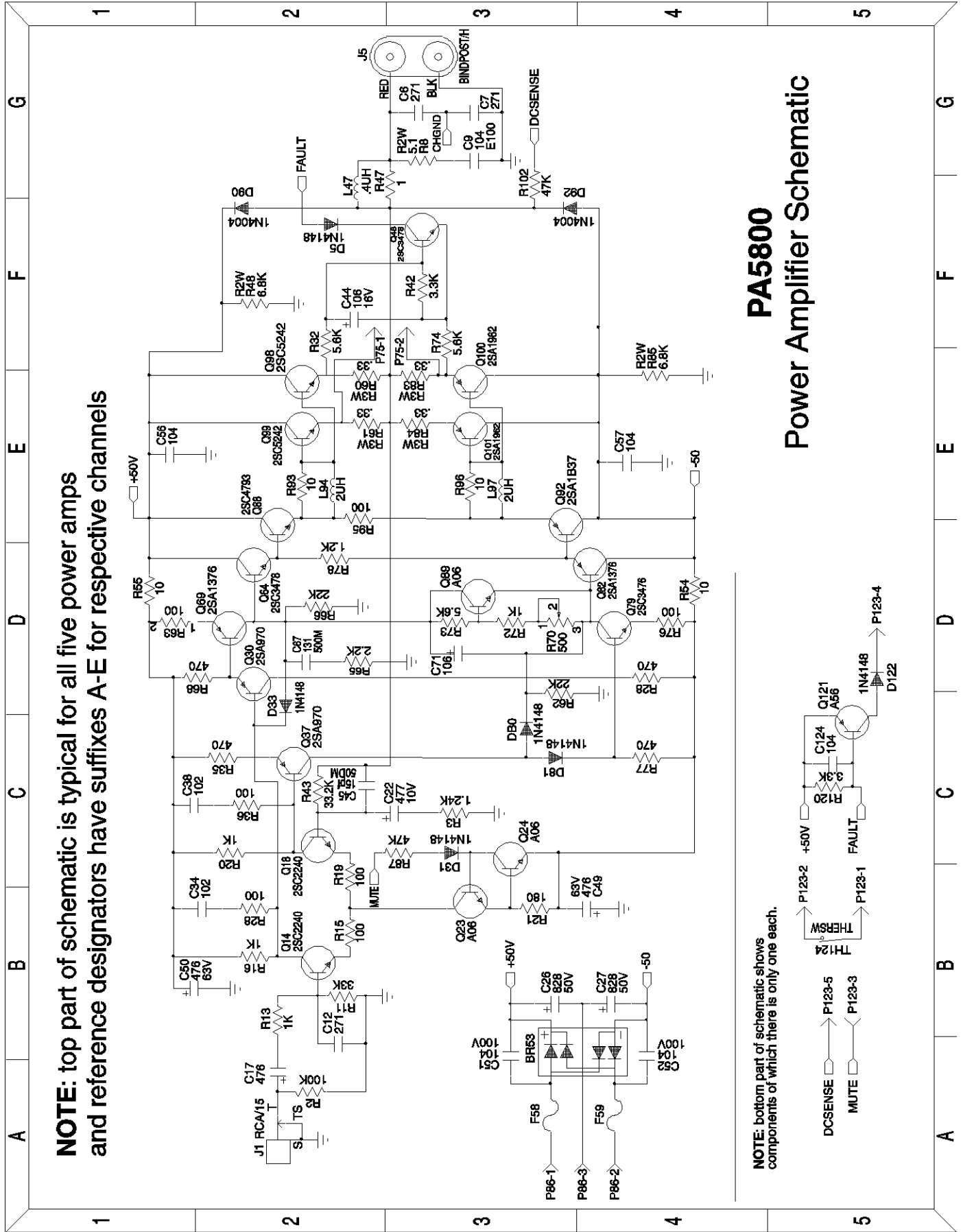

NOTE: top part of schematic is typical for all five power amps and reference designators have suffixes A-E for respective channels

PA5800
Power Amplifier Schematic

NOTE: bottom part of schematic shows components of which there is only one each.

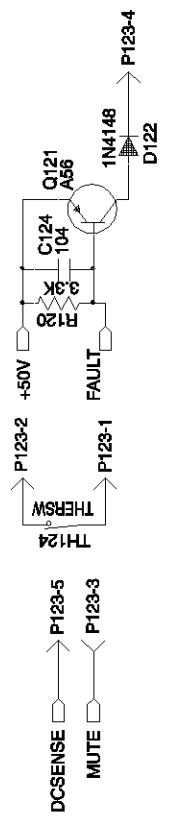

Signature 2.1 POWER SWITCH/INDICATOR SCHEMATIC (1 of 1)

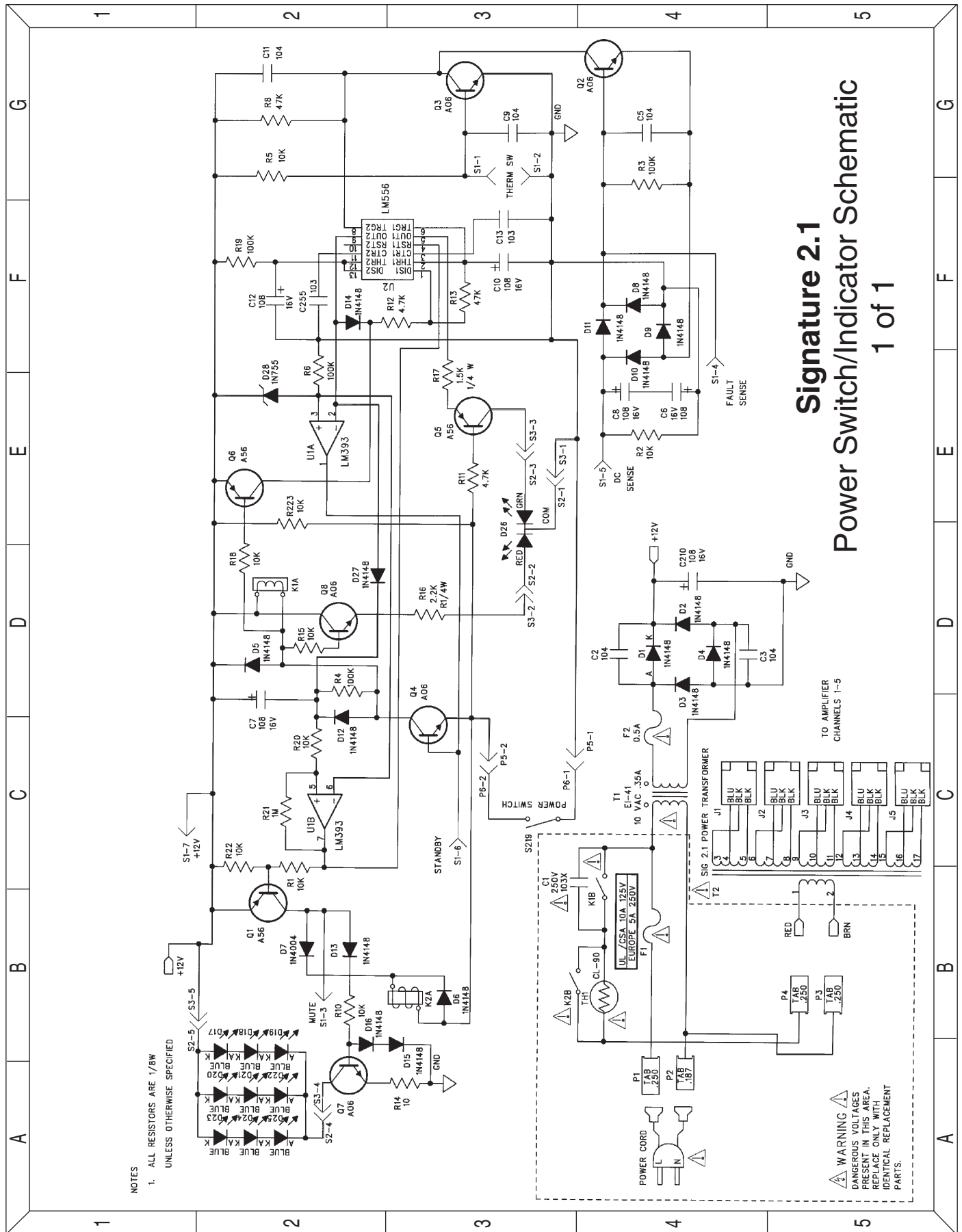

Signature 2.1
Power Switch/Indicator Schematic
1 of 1

NOTES
1. ALL RESISTORS ARE 1/BW UNLESS OTHERWISE SPECIFIED

WARNING
DANGEROUS VOLTAGES PRESENT IN THIS AREA. REPLACE ONLY WITH IDENTICAL REPLACEMENT PARTS.

Signature 2.1 POWER AMP SCHEMATIC (1 of 5)

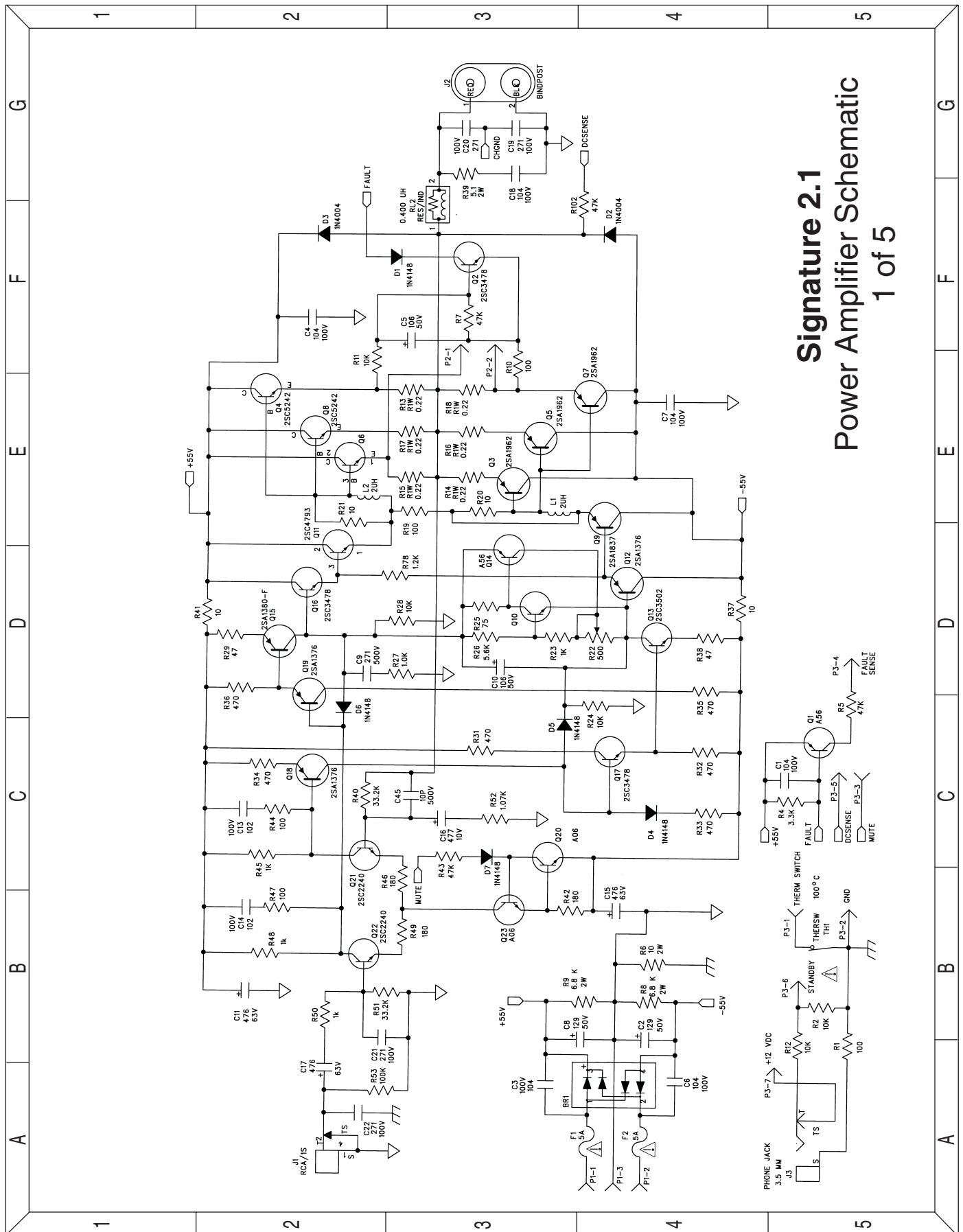

Signature 2.1
Power Amplifier Schematic
1 of 5

Signature 2.1 POWER AMP SCHEMATIC (2 of 5)

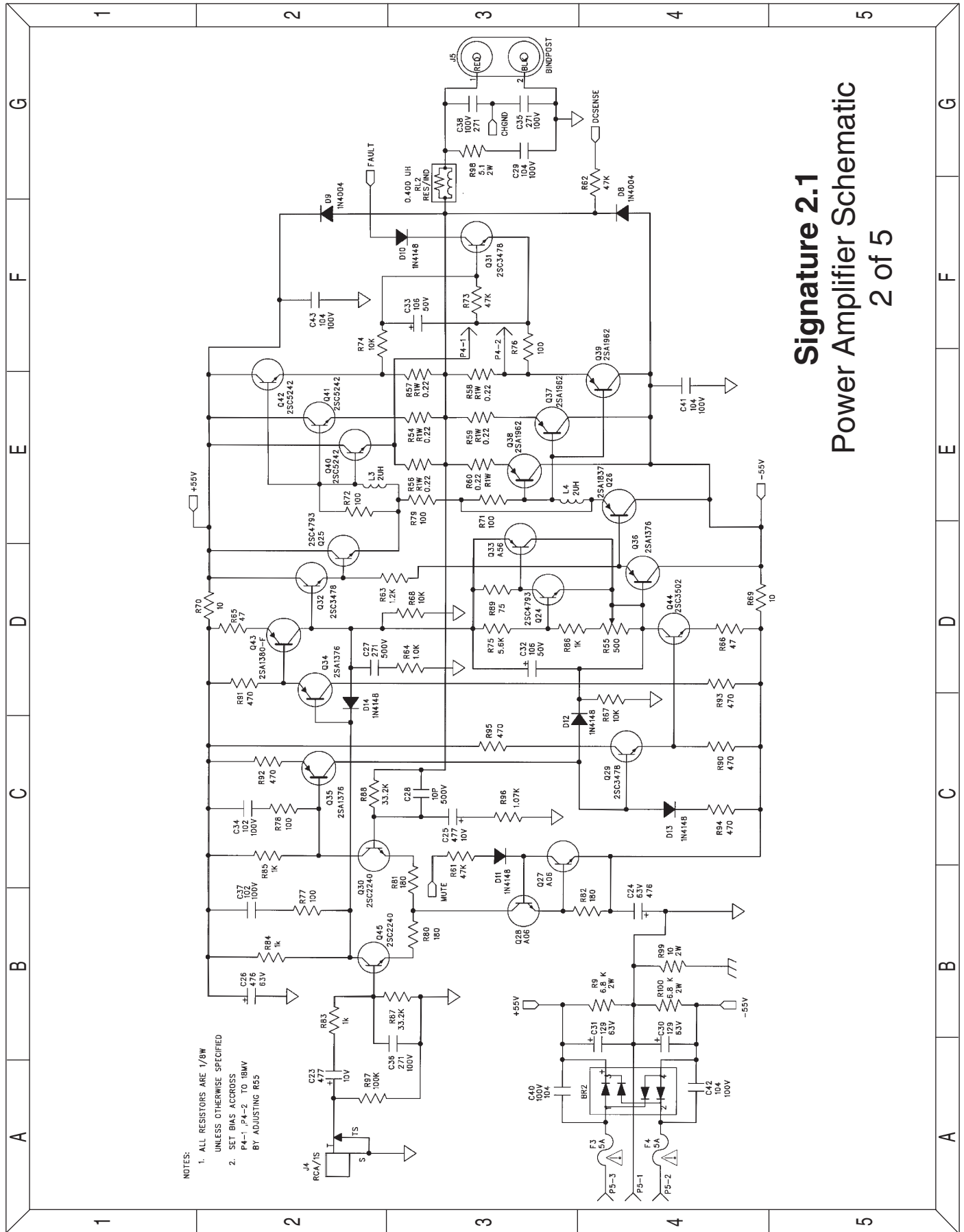

- NOTES:
- 1. ALL RESISTORS ARE 1/8W UNLESS OTHERWISE SPECIFIED
 - 2. SET BIAS ACCROSS P4-1, P4-2 TO 18W BY ADJUSTING R55

Signature 2.1
Power Amplifier Schematic
2 of 5

Signature 2.1 POWER AMP SCHEMATIC (4 of 5)

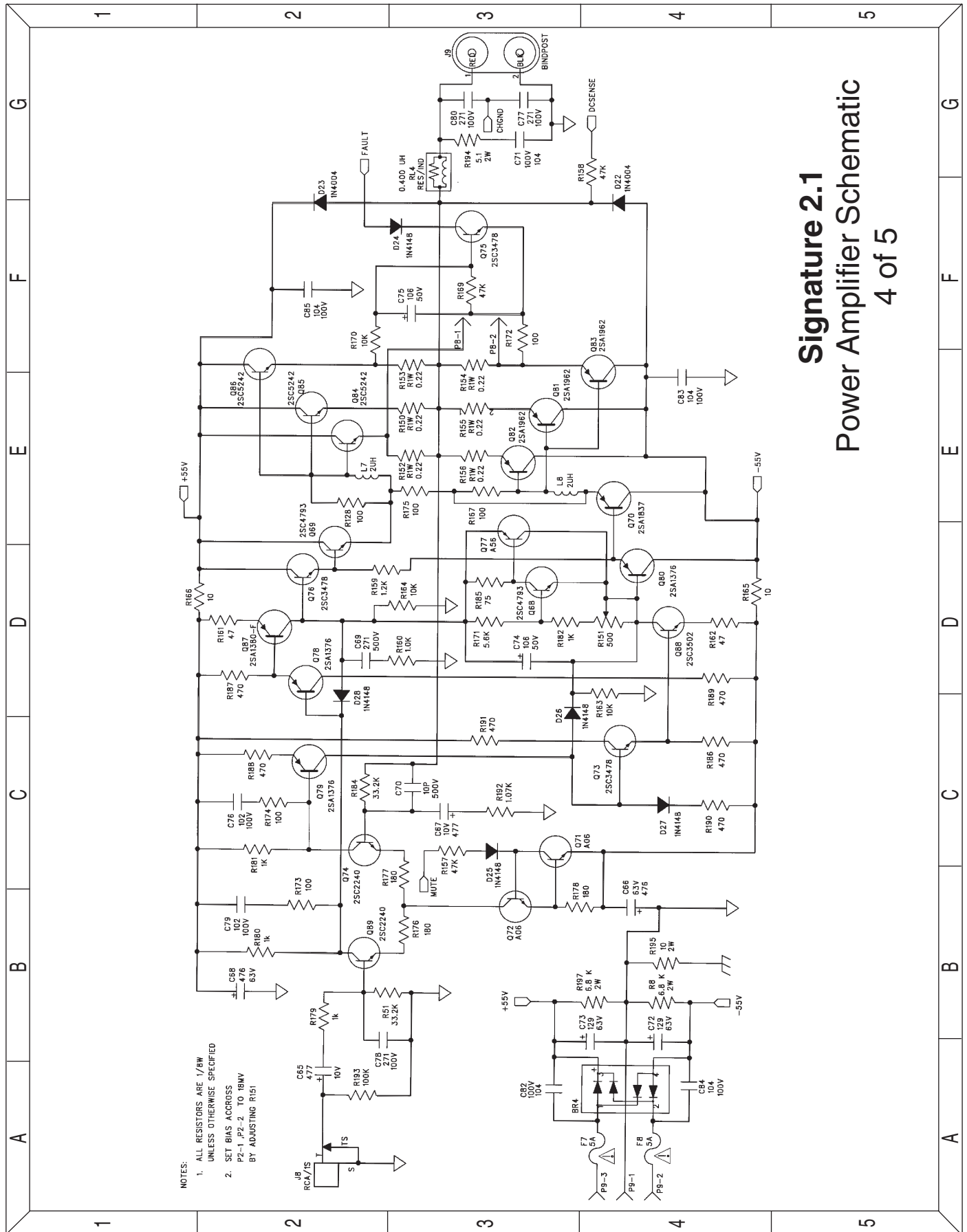

- NOTES:
- 1. ALL RESISTORS ARE 1/8W UNLESS OTHERWISE SPECIFIED
 - 2. SET BIAS ACROSS P2-1, P2-2 TO 18MV BY ADJUSTING R151

Signature 2.1
Power Amplifier Schematic
4 of 5

Signature 2.1 POWER AMP SCHEMATIC (5 of 5)

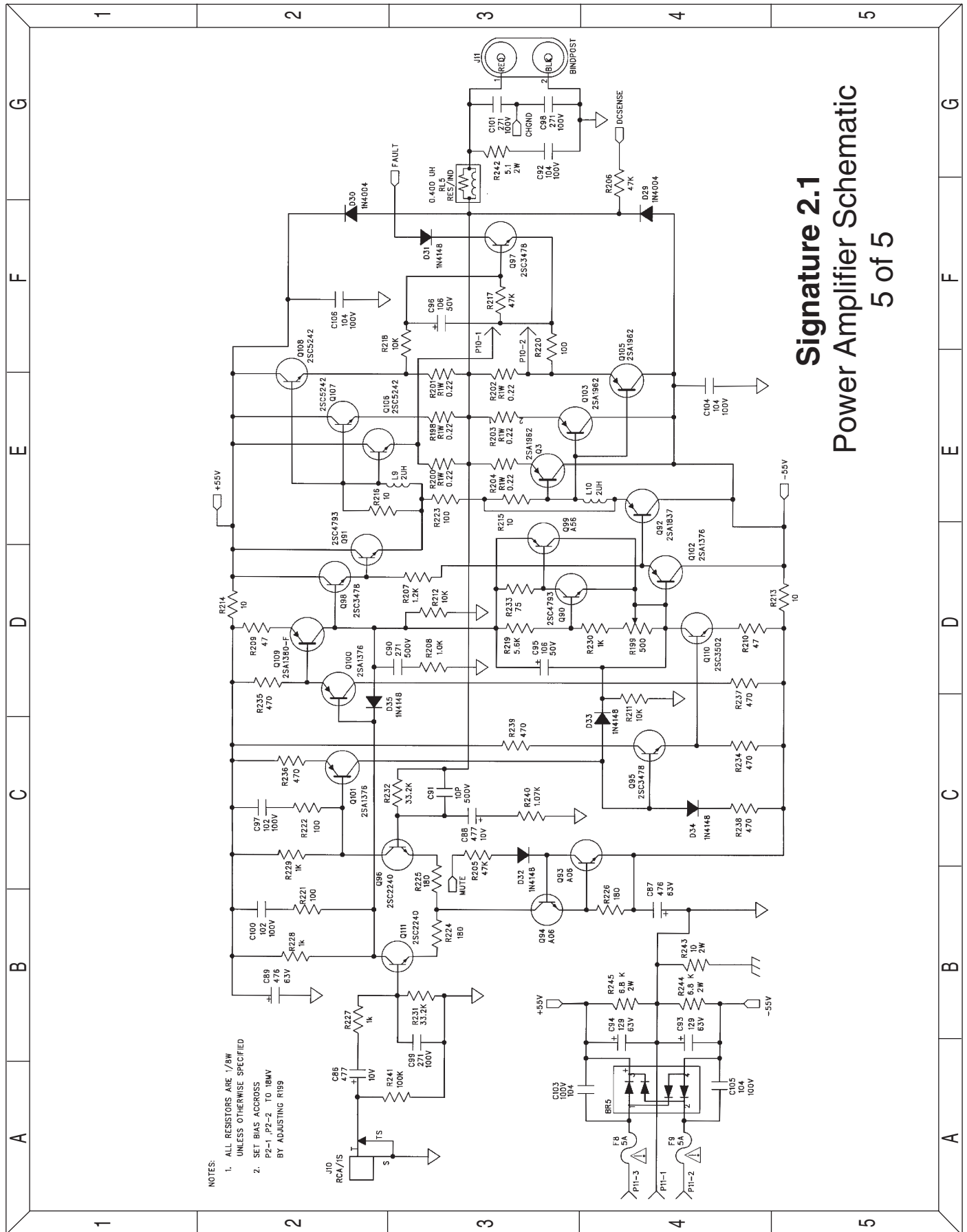

NOTES:
1. ALL RESISTORS ARE 1/8W UNLESS OTHERWISE SPECIFIED
2. SET BIAS ACCROSS P2-1, P2-2 TO 18MV BY ADJUSTING R199

Signature 2.1
Power Amplifier Schematic
5 of 5